

# M300 SERIES

## INSTALLATION & OPERATION INSTRUCTIONS



English (en-US)  
Date: 01-2023  
Document number: 71004 (Rev 5)  
© 2023 Teledyne FLIR LLC





## Legal notices (Teledyne FLIR)

### Trademark and patents notice

**FLIR, Instalert, Infrared Everywhere, The World's Sixth Sense** and **ClearCruise** are registered or claimed trademarks of Teledyne FLIR LLC.

All other trademarks, trade names, or company names referenced herein are used for identification only and are the property of their respective owners.

This product is protected by patents, design patents, patents pending, or design patents pending.

### Fair Use Statement

You may print no more than three copies of this manual for your own use. You may not make any further copies or distribute or use the manual in any other way including without limitation exploiting the manual commercially or giving or selling copies to third parties.

### Patents notice

This product is covered by one or more of US Patent Nos: 7470904; 7034301; 6812465; 7470902; 6929410 and other patents pending, or design patents pending.

### Export control

M300 Series thermal cameras are controlled by US export laws.

There are special versions of the system that are approved for international distribution and travel. Please contact FLIR customer support if you have any questions.

Contact details can be found on the FLIR website, [www.flir.com](http://www.flir.com).

### WARNING — Export Controlled Information (ECI)

---

**Important:**

This document contains technology subject to the (US) Export Administration Regulations (EAR) (15. C.F.R. Sections 730-744).

---

**Important:**

Information contained herein is Technology controlled under the (EU) Regulation (EC) No 2021/821 and/or EU Member State regulations. Export or diversion contrary to law is prohibited.

---

**Important:**

Information contained herein is Technology controlled under (UK) Export Control Order 2008. Export or diversion contrary to law is prohibited.

[English \(en-US\)](#)

Document number: 71004 (Rev 5)

AE;40047;2023-01-19T10:33:49



# CONTENTS

<b>CHAPTER 1 IMPORTANT INFORMATION.....</b>	<b>9</b>	<b>CHAPTER 3 PRODUCT AND SYSTEM OVERVIEW .....</b>	<b>17</b>
Safety warnings .....	9	3.1 Product overview .....	18
Product warnings .....	9	M300 (single payload).....	18
Regulatory notices.....	10	M300 (dual payload).....	18
Cleaning the camera .....	10	3.2 System overview.....	19
Inspecting the thermal camera.....	11	3.3 Control options .....	21
Water ingress .....	11	3.4 Display options.....	21
Disclaimer.....	11	3.5 Multicasting .....	22
EMC installation guidelines.....	11	3.6 Enabling multicasting.....	22
Suppression ferrites.....	11	3.7 Compatible joystick controllers (JCU).....	22
Connections to other equipment.....	12	3.8 Compatible multifunction displays .....	23
Declaration of Conformity.....	12	<b>CHAPTER 4 PARTS SUPPLIED .....</b>	<b>24</b>
Product disposal .....	12	4.1 Parts supplied.....	25
Warranty registration .....	12	<b>CHAPTER 5 PRODUCT DIMENSIONS .....</b>	<b>26</b>
IMO and SOLAS .....	12	5.1 Product dimensions .....	27
Technical accuracy.....	12	M300 Series.....	27
Publication copyright .....	13	M300 Series with optional mounting riser .....	27
<b>CHAPTER 2 DOCUMENT INFORMATION.....</b>	<b>14</b>	Mounting riser.....	28
2.1 Document information .....	15	<b>CHAPTER 6 LOCATION REQUIREMENTS .....</b>	<b>29</b>
2.2 Applicable products.....	15	6.1 General location requirements .....	30
2.3 Additional system components .....	16	Compass safe distance .....	30
2.4 Product documentation .....	16	6.2 Location requirements — Camera .....	30
2.5 Operation instructions .....	16	<b>CHAPTER 7 MOUNTING.....</b>	<b>32</b>
2.6 Multifunction display software version.....	16	7.1 Tools required .....	33

7.2 Camera orientation.....	33	11.1 Network connections.....	48
Ball-down (upside down) mounting: rotating		Single-camera system with a compatible	
the front cover .....	34	MFD and JCU.....	48
7.3 Camera mounting .....	34	Single-camera system with a digital video	
Inserting the studs into the camera base .....	34	(HD-SDI) monitor and JCU .....	49
Mounting the camera.....	35	Single-camera system with a digital video	
<b>CHAPTER 8 CONNECTIONS OVERVIEW .....</b>	<b>36</b>	(HDMI) monitor and JCU .....	50
8.1 Connections overview .....	37	Single-camera system with an analog video	
Connecting cables.....	38	monitor and JCU.....	51
Orientation of right-angled connectors.....	38	Single-camera system connected to a	
8.2 General cabling guidance.....	38	third-party radar with an analog video monitor	
Cable types and length .....	38	and JCU .....	51
Cable routing .....	39	Single-camera system with direct connection	
Strain relief.....	39	to a Web browser .....	52
Circuit isolation.....	39	Single-camera system with a Web browser	
Cable shielding .....	39	and an optional JCU .....	53
<b>CHAPTER 9 VIDEO CONNECTIONS.....</b>	<b>40</b>	Multi-camera system with a digital video	
9.1 Video connections .....	41	monitor, 2 compatible MFDs, 2 JCUs and a	
Video and network cables .....	43	Web browser .....	54
HD-SDI cable connection .....	43	11.2 Multicasting .....	54
<b>CHAPTER 10 NMEA 0183 CONNECTION.....</b>	<b>44</b>	11.3 Enabling multicasting.....	55
10.1 NMEA 0183 connection .....	45	<b>CHAPTER 12 POWER CONNECTIONS .....</b>	<b>56</b>
10.2 NMEA 0183 overview .....	45	12.1 Power connection.....	57
10.3 Enabling NMEA features .....	46	Inline fuse and thermal breaker ratings.....	57
<b>CHAPTER 11 NETWORK CONNECTIONS.....</b>	<b>47</b>	Power distribution.....	57
		Power cable drain wire connection .....	59

<b>CHAPTER 13 CAMERA CONTROL OPTIONS AND STATUS ICONS</b> .....	<b>61</b>	<b>CHAPTER 15 CAMERA OPERATION VIA JCU</b> .....	<b>82</b>
13.1 Camera control options .....	62	15.1 JCU operation .....	83
13.2 Camera image .....	62	15.2 JCU-2 controls overview .....	83
Thermal Camera .....	62	Configuring JCU-2 user-programmable	
Camera status icons .....	62	buttons (UPBs) .....	84
Image adjustments .....	65	<b>CHAPTER 16 CAMERA OPERATION VIA MFD</b> .....	<b>86</b>
13.3 Camera control .....	66	16.1 Overview .....	87
Pan, tilt and zoom .....	66	<b>CHAPTER 17 MARINE VIDEO ANALYTICS</b>	
Forward position .....	67	<b>(MVA)</b> .....	<b>88</b>
Home position .....	67	17.1 Overview .....	89
Surveillance mode .....	67	17.2 Enabling MVA via the camera's Web	
<b>CHAPTER 14 CAMERA OPERATION VIA WEB</b>		interface .....	89
<b>BROWSER</b> .....	<b>68</b>	17.3 Enabling MVA via the camera's on-screen	
14.1 Web browser user interface overview .....	69	display and JCU .....	90
14.2 Setting up a network connection to the		<b>CHAPTER 18 NMEA (RADAR TRACKING)</b> .....	<b>92</b>
camera .....	69	18.1 NMEA 0183 overview .....	93
14.3 Logging in to the Web browser user		18.2 Enabling NMEA 0183 via the camera's web	
interface .....	70	interface .....	93
First time login .....	71	18.3 Enabling NMEA 0183 via the camera's	
14.4 Video feed .....	71	on-screen display .....	94
14.5 OSD Menu .....	72	<b>CHAPTER 19 MAINTENANCE</b> .....	<b>95</b>
14.6 OSD Settings .....	72	19.1 Service and maintenance .....	96
14.7 Camera settings menus .....	75	19.2 Cleaning the camera .....	96
14.8 Camera settings .....	76	<b>CHAPTER 20 SYSTEM CHECKS AND</b>	
14.9 System settings .....	81	<b>TROUBLESHOOTING</b> .....	<b>97</b>
14.10 Troubleshooting .....	81	20.1 Thermal camera troubleshooting .....	98
Setting a static IP address .....	81	20.2 Teledyne FLIR Maritime product support and	
		servicing .....	99

CHAPTER 21 TECHNICAL SPECIFICATION.....	100
21.1 Physical specification .....	101
21.2 Power specification .....	101
21.3 Environmental specification .....	101
21.4 Video specification .....	102
21.5 Conformance specification .....	102
21.6 Sensor specification.....	103
CHAPTER 22 SPARES AND ACCESSORIES .....	104
22.1 M300 Series camera spares and accessories .....	105
22.2 FLIR networking accessories .....	106
22.3 RayNet to RayNet cables and connectors.....	108
22.4 RayNet to RJ45, and RJ45 (SeaTalkhs) adapter cables.....	109
APPENDIX A SUPPORTED NMEA 0183 SENTENCES.....	111
APPENDIX B SUPPORTED NMEA 2000 PGNS.....	111

# CHAPTER 1: IMPORTANT INFORMATION

## Safety warnings



### Warning: Product installation and operation

- This product must be installed and operated in accordance with the instructions provided. Failure to do so could result in personal injury, damage to your vessel and/or poor product performance.
- Certified installation by an approved installer is recommended. A certified installation qualifies for enhanced product warranty benefits. Contact your dealer for further details, and refer to the separate warranty document packed with your product.



### Warning: Potential ignition source

This product is NOT approved for use in hazardous/flammable atmospheres. Do NOT install in a hazardous/flammable atmosphere (such as in an engine room or near fuel tanks).



### Warning: Switch off power supply

Ensure the vessel's power supply is switched OFF before starting to install this product. Do NOT connect or disconnect equipment with the power switched on, unless instructed in this document.



### Warning: Entrapment hazard

This product features moving parts that provide a potential entrapment hazard. Keep clear of moving parts at all times.



### Warning: Ensure safe navigation

This product is intended only as an aid to navigation and must never be used in preference to sound navigational judgment. Only official government charts and notices to mariners contain all the current information needed for safe navigation, and the captain is responsible for their prudent use. It is the user's responsibility to use official government charts, notices to mariners, caution and proper navigational skill when operating this or any other product.



### Warning: Maintain a permanent watch

Always maintain a permanent watch, this will allow you to respond to situations as they develop. Failure to maintain a permanent watch puts yourself, your vessel and others at serious risk of harm.

## Product warnings



### Warning: Product grounding

Before applying power to this product, ensure it has been correctly grounded, in accordance with the instructions provided.



### Warning: Positive ground systems

Do not connect this unit to a system which has positive grounding.



### Warning: Power supply voltage

Connecting this product to a voltage supply greater than the specified maximum rating may cause permanent damage to the unit. Refer to the product's information label for the correct voltage.



### **Warning: PoE isolation coupler**

Some networks require an inline Power over Ethernet (PoE) isolation coupler to be fitted before the camera can be connected to the network.

The inline PoE isolation coupler may be required regardless of whether a network device (e.g. a multifunction display or network switch) outputs PoE or not.

Before connecting the camera to a network, refer to your network device manufacturer for more information.



### **Warning: Corrosion**

To avoid accelerated galvanic corrosion of the product, ensure that a non-metallic isolation mount is used when fitting the product directly to large stainless steel platforms/mounts, or directly to steel construction vessels.

### **Caution: Power supply protection**

When installing this product ensure the power source is adequately protected by means of a suitably-rated fuse or thermal circuit breaker.

### **Caution: Sun covers**

- If your product is supplied with a sun cover, to protect against the damaging effects of ultraviolet (UV) light, always fit the sun cover when the product is not in use.
- To avoid potential loss, sun covers must be removed when travelling at high speed, whether in water or when the vessel is being towed.

### **Caution: Do not open the unit**

The unit is factory sealed to protect against atmospheric humidity, suspended particulates and other contaminants. It is important that you do not open the unit or remove the casing for any reason. Opening the unit will:

- compromise the seal with possible damage to the unit, and
- void the manufacturer's warranty.

### **Caution: Service and maintenance**

This product contains no user serviceable components. Please refer all maintenance and repair to authorized FLIR dealers. Unauthorized repair may affect your warranty.

## **Regulatory notices**

### **Cleaning the camera**

The camera housing and lens will require occasional cleaning. You should clean the lens when image quality degradation is noticed or excessive contaminant buildup is seen. Clean the interface between the yoke and base often to prevent accumulation of debris or salt deposits.

When cleaning this product:

- Do NOT wipe the lens window with a dry cloth, or with abrasive materials such as paper or scrub brushes, as this could scratch the coating.
- Do NOT use acid or ammonia based products.
- Do NOT pressure wash.

Particular care should be taken when cleaning the lens window, this has a protective anti-reflective coating which may be damaged by improper cleaning.

1. Switch off the power to the unit.
2. Clean the camera body with a clean, soft cotton cloth. You can moisten the cloth and use a mild detergent if required.
3. Clean the camera lens.

- Rinse the lens with fresh water to remove all dirt particles and salt deposits, and allow to dry naturally.
- If any spots or smears remain, very gently wipe the lens window with a clean microfibre cloth or soft cotton cloth.
- If necessary, use isopropyl alcohol (IPA) or a mild detergent to remove any remaining spots or marks.

## Inspecting the thermal camera

Routinely inspect the camera and its mounting surface to ensure that it is installed securely, that the coated surfaces are intact, and that there are no signs of corrosion.

When the camera is powered off, grasp it firmly at the base and confirm it is rigid and secure. Then hold the camera above the base and confirm it will rotate freely and without noticeable wobble or looseness around the pan bearing.

## Water ingress

Water ingress disclaimer

Although the waterproof rating capacity of this product meets the stated standard (refer to the product's *Technical Specification*), water intrusion and subsequent equipment failure may occur if the product is subjected to commercial high-pressure washing. FLIR will not warrant products subjected to high-pressure washing.

## Disclaimer

FLIR does not warrant that this product is error-free or that it is compatible with products manufactured by any person or entity other than FLIR.

FLIR is not responsible for damages or injuries caused by your use or inability to use the product, by the interaction of the product with products manufactured by others, or by errors in information utilized by the product supplied by third parties.

## EMC installation guidelines

FLIR equipment and accessories conform to the appropriate Electromagnetic Compatibility (EMC) regulations, to minimize electromagnetic interference between equipment and minimize the effect such interference could have on the performance of your system

[Important information](#)

Correct installation is required to ensure that EMC performance is not compromised.

### Note:

In areas of extreme EMC interference, some slight interference may be noticed on the product. Where this occurs the product and the source of the interference should be separated by a greater distance.

For **optimum** EMC performance we recommend that wherever possible:

- FLIR equipment and cables connected to it are:
  - At least 1 m (3.3 ft) from any equipment transmitting or cables carrying radio signals e.g. VHF radios, cables and antennas. In the case of SSB radios, the distance should be increased to 2 m (6.6 ft).
  - More than 2 m (6.6 ft) from the path of a radar beam. A radar beam can normally be assumed to spread 20 degrees above and below the radiating element.
- The product is supplied from a separate battery from that used for engine start. This is important to prevent erratic behavior and data loss which can occur if the engine start does not have a separate battery.
- FLIR specified cables are used.
- Cables are not cut or extended, unless doing so is detailed in the installation manual.

### Note:

**Where constraints on the installation prevent any of the above recommendations**, always ensure the maximum possible separation between different items of electrical equipment, to provide the best conditions for EMC performance throughout the installation

## Suppression ferrites

- Cables may be pre-fitted or supplied with suppression ferrites. These are important for correct EMC performance. If ferrites are supplied separately to the cables (i.e. not pre-fitted), you must fit the supplied ferrites, using the supplied instructions.
- If a ferrite has to be removed for any purpose (e.g. installation or maintenance), it must be replaced in the original position before the product is used.

- Use only ferrites of the correct type, supplied by the manufacturer or its authorized dealers.
- Where an installation requires multiple ferrites to be added to a cable, additional cable clips should be used to prevent stress on the connectors due to the extra weight of the cable.
- If your camera installation requires long cable runs, you may need to fit additional ferrites to maintain acceptable EMC performance.

## Connections to other equipment

Requirement for ferrites on non-FLIR cables

If your FLIR equipment is to be connected to other equipment using a cable not supplied by FLIR, a suppression ferrite **MUST** always be attached to the cable near the FLIR unit.

## Declaration of Conformity

FLIR Belgium BVBA declares that the following products are in compliance with the EMC Directive 2014/30/EU:

- M364C 30 Hz dual payload thermal camera, part number E70518
- M364C 9 Hz dual payload thermal camera, part number E70519
- M364C 30 Hz dual payload thermal camera, part number E70520
- M364C 9 Hz dual payload thermal camera, part number E70521
- M364 30 Hz single payload thermal camera, part number E70525
- M364 9 Hz single payload thermal camera, part number E70526
- M332 30 Hz single payload thermal camera, part number E70527
- M332 9 Hz single payload thermal camera, part number E70528
- M300C 30 Hz single payload camera, part number E70605

The original Declaration of Conformity certificate may be viewed on the relevant product page at [www.flir.com/marine](http://www.flir.com/marine).

## Product disposal

Dispose of this product in accordance with the WEEE Directive.

The Waste Electrical and Electronic Equipment (WEEE) Directive requires the recycling of waste electrical and electronic equipment which contains materials, components and substances that may be hazardous and present a risk to human health and the environment when WEEE is not handled correctly.

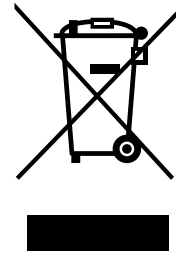

Equipment marked with the crossed-out wheeled bin symbol indicates that the equipment should not be disposed of in unsorted household waste. Local authorities in many regions have established collection schemes under which residents can dispose of waste electrical and electronic equipment at a recycling center or other collection point. For more information about suitable collection points for waste electrical and electronic equipment in your region, refer to the Raymarine website: [www.raymarine.eu/recycling](http://www.raymarine.eu/recycling).

## Warranty registration

To register your FLIR product ownership, please visit [www.flir.com](http://www.flir.com) and register online.

It is important that you register your product to receive full warranty benefits. Your unit package includes a bar code label indicating the serial number of the unit. You will need this serial number when registering your product online. You should retain the label for future reference.

## IMO and SOLAS

The equipment described within this document is intended for use on leisure marine boats and workboats NOT covered by International Maritime Organization (IMO) and Safety of Life at Sea (SOLAS) Carriage Regulations.

## Technical accuracy

To the best of our knowledge, the information in this document was correct at the time it was produced. However, FLIR cannot accept liability for any inaccuracies or omissions it may contain. In addition, our policy of continuous product improvement may change specifications without notice. As a result, FLIR cannot accept liability for any differences

between the product and this document. Please check the FLIR website ([www.flir.com/marine/support](http://www.flir.com/marine/support)) to ensure you have the most up-to-date version(s) of the documentation for your product.

## **Publication copyright**

**Copyright © 2023 Teledyne FLIR LLC. All rights reserved. No parts of this material may be copied, translated, or transmitted (in any medium) without the prior written permission of Teledyne FLIR LLC.**

# CHAPTER 2: DOCUMENT INFORMATION

## CHAPTER CONTENTS

- 2.1 Document information — page 15
- 2.2 Applicable products — page 15
- 2.3 Additional system components — page 16
- 2.4 Product documentation — page 16
- 2.5 Operation instructions — page 16
- 2.6 Multifunction display software version — page 16

## 2.1 Document information

This document contains important information related to the installation and operation of your FLIR product.

The document includes information to help you:

- Plan your installation and ensure you have all the necessary equipment;
- Install and connect your product as part of a wider system of connected marine electronics;
- Use your product along with an appropriate video monitor, joystick control unit (JCU), Web browser, or multifunction display (MFD).
- Troubleshoot problems and obtain technical support if required.

This and other FLIR product documents are available to download in PDF format from [www.flir.com/marine/support](http://www.flir.com/marine/support).

## 2.2 Applicable products

This document is applicable to the following products:

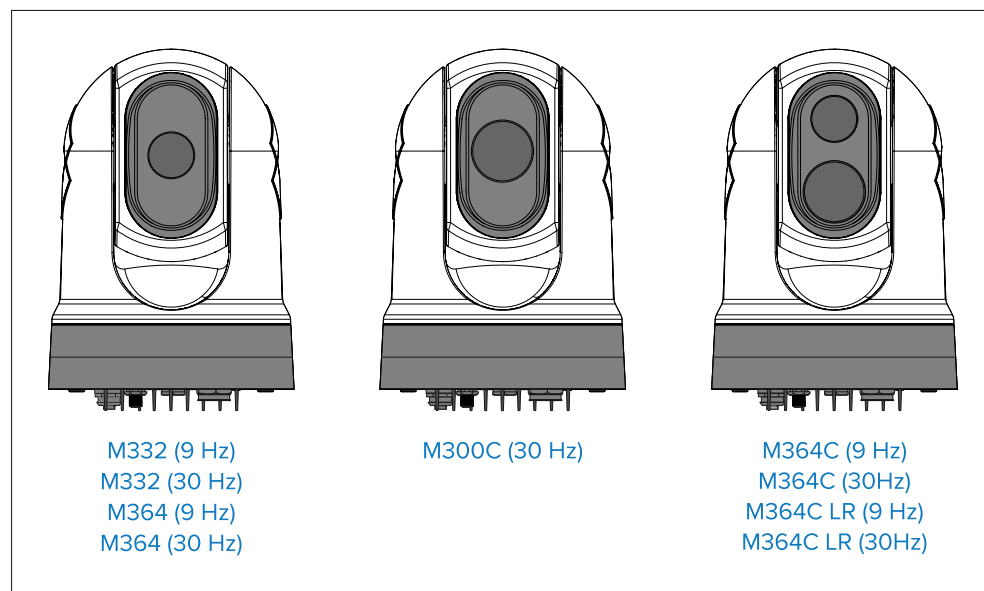

Camera (Single Payload)	Description
M332 (9 Hz) — (E70528)	<ul style="list-style-type: none"> <li>• 24° Field of View (FOV)</li> <li>• 320px thermal sensor resolution</li> </ul>
M332 (30 Hz) — (E70527)	<ul style="list-style-type: none"> <li>• 24° Field of View (FOV)</li> <li>• 320px thermal sensor resolution</li> </ul>
M364 (9 Hz) — (E70526)	<ul style="list-style-type: none"> <li>• 24° Field of View (FOV)</li> <li>• 640px thermal sensor resolution</li> </ul>
M364 (30 Hz) — (E70525)	<ul style="list-style-type: none"> <li>• 24° Field of View (FOV)</li> <li>• 640px thermal sensor resolution</li> </ul>
M300C (30 Hz) — (E70605)	<ul style="list-style-type: none"> <li>• DLTV visible light optical sensor with 1080p resolution and 30x zoom</li> </ul>

Camera (Dual Payload)	Description
M364C LR (9 Hz) — (E70521)	<ul style="list-style-type: none"> <li>• 18° Field of View (FOV)</li> <li>• 640px thermal sensor resolution</li> <li>• DLTV visible light optical sensor with 1080p resolution and 30x zoom</li> </ul>
M364C LR (30 Hz) — (E70520)	<ul style="list-style-type: none"> <li>• 18° Field of View (FOV)</li> <li>• 640px thermal sensor resolution</li> <li>• DLTV visible light optical sensor with 1080p resolution and 30x zoom</li> </ul>
M364C (9 Hz) — (E70519)	<ul style="list-style-type: none"> <li>• 24° Field of View (FOV)</li> <li>• 640px thermal sensor resolution</li> <li>• DLTV visible light optical sensor with 1080p resolution and 30x zoom</li> </ul>
M364C (30 Hz) — (E70518)	<ul style="list-style-type: none"> <li>• 24° Field of View (FOV)</li> <li>• 640px thermal sensor resolution</li> <li>• DLTV visible light optical sensor with 1080p resolution and 30x zoom</li> </ul>

## 2.3 Additional system components

M300 Series thermal cameras can be used in conjunction with the following optional items, available separately from FLIR:

- **JCU-2:** A remote keypad for FLIR thermal cameras (500–0398–10). Each JCU-2 keypad can interact and be paired with multiple supported thermal cameras, and each camera can be paired to multiple keypads. The JCU-2 requires a PoE power connection (e.g. via a PoE Injector or a PoE compatible network switch).
- **JCU-1** and **JCU-3:** For more information on these remote keypads, refer to: [p.22 — Compatible joystick controllers \(JCU\)](#)

## 2.4 Product documentation

The following documentation is applicable to your product:

Description	Part number
<b>M300 Thermal Camera Installation and Operation Instructions (this document)</b> Installation and operation of an M300 Series thermal camera and connection to a wider system of marine electronics.	71004
<b>M300 Series surface mounting template</b> Cut out template for mounting an M300 Series thermal camera.	77005
<b>M300 Series riser mounting template</b> Drill template for mounting the camera riser.	77006
<b>M300 Thermal Camera Raymarine System Integration Guide</b> Integration of an M300 Series thermal camera within a Raymarine system of marine electronics.	81400
<b>JCU-2 Remote Keypad Installation Instructions</b> Installation of a JCU-2 Remote Keypad and connection to a wider system of marine electronics.	71005

## 2.5 Operation instructions

For detailed operation instructions for your product, refer to the documentation that accompanies your display.

## 2.6 Multifunction display software version

When using the camera with a multifunction display (MFD), ensure that the MFD is using the latest software version.

For instructions on how to update the software, refer to the documentation that accompanies your MFD.

# CHAPTER 3: PRODUCT AND SYSTEM OVERVIEW

## CHAPTER CONTENTS

- 3.1 Product overview — page 18
- 3.2 System overview — page 19
- 3.3 Control options — page 21
- 3.4 Display options — page 21
- 3.5 Multicasting — page 22
- 3.6 Enabling multicasting — page 22
- 3.7 Compatible joystick controllers (JCU) — page 22
- 3.8 Compatible multifunction displays — page 23

## 3.1 Product overview

### M300 (single payload)

The M300 Series single payload variant is a maritime camera equipped with either a visible or thermal imaging system (depending on chosen model), for use on nearly any kind of vessel.

The camera will have one of the following types of imaging core, depending on the chosen model:

- **Visible** — provides a clear color image in daylight conditions. For example, a visible camera can help you maintain a watch of your surroundings, or zoom in on distant objects.
- **Thermal** — provides a clear image in faint and no-light conditions. For example, a thermal camera can help you navigate at night or identify obstacles in areas of low visibility, or even total darkness.

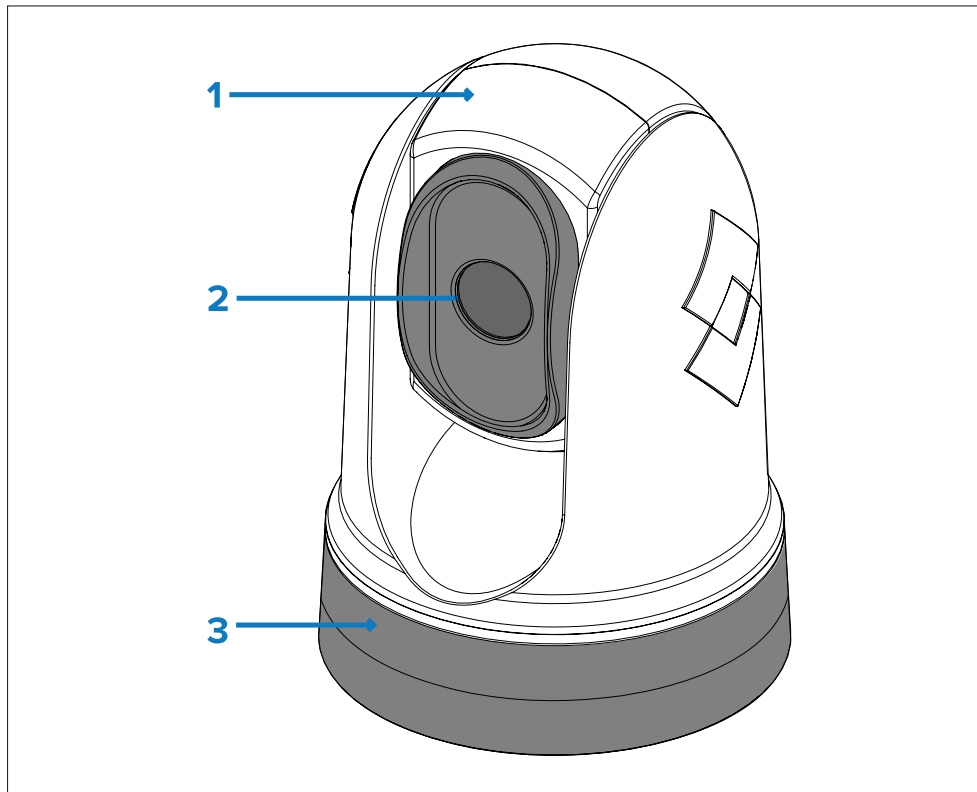

1. Tilt assembly.
2. Camera lens window.
3. Pan assembly.

The M300 Series system has the following key functions and features:

- IP connectivity to simplify installation and system integration.
- 4 simultaneous video outputs, including 2 visible or 2 thermal digital streams (depending on your chosen model). For further information, refer to the following section: [p.41 — Video connections](#)
- Pan and tilt operations with dedicated joystick control unit, multifunction display (MFD), or Web browser.
- 2 axis mechanical camera stabilization to suit changing conditions.
- Preset modes (Scenes) optimized for prevailing conditions.
- Marine Video Analytics (MVA) — intelligent thermal analytics technology; provides visual alerts when “non-water” objects are identified in the scene. This feature can be enabled using the camera’s Web interface or the on-screen display via a connected JCU.
- Automatic window heaters to de-ice the lens window in cold weather.
- 12 V or 24 V dc power.

### M300 (dual payload)

The M300 Series dual payload variant is a maritime camera equipped with a visible and thermal imaging system, for use on nearly any kind of vessel.

Dual payload cameras have 2 separate imaging cores:

- **Visible** — provides a clear color image in daylight conditions. For example, a visible camera can help you maintain a watch of your surroundings, or zoom in on distant objects.
- **Thermal** — provides a clear image in faint and no-light conditions. For example, a thermal camera can help you navigate at night or identify obstacles in areas of low visibility, or even total darkness.

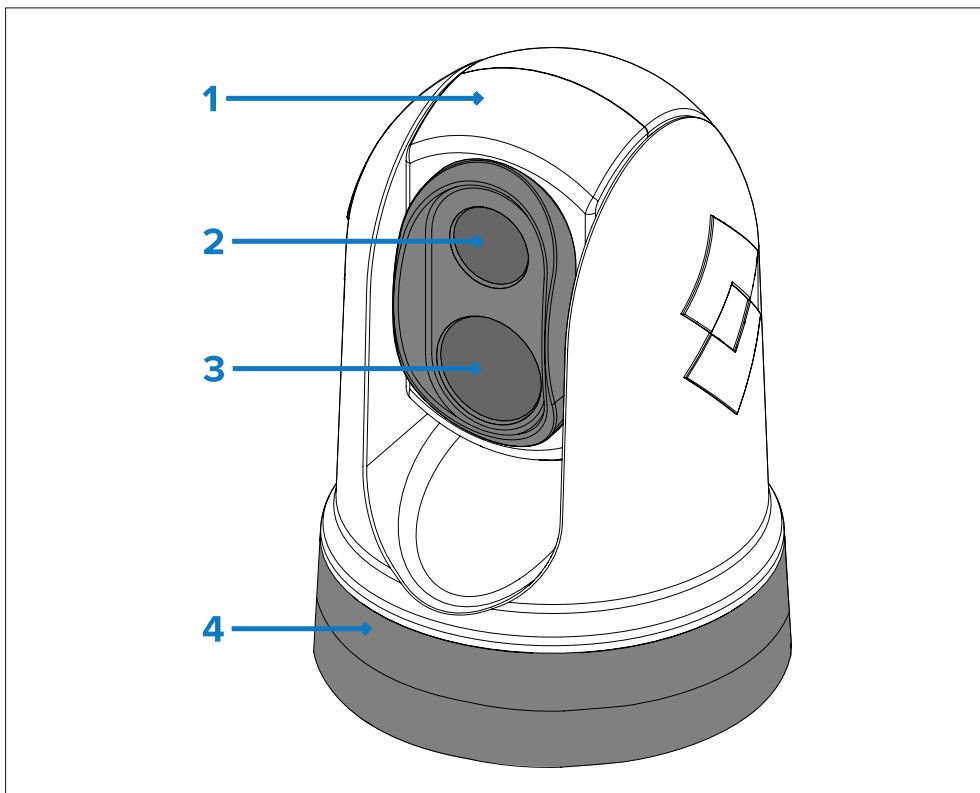

1. Tilt assembly.
2. Thermal camera lens window.
3. Visible camera lens window.
4. Pan assembly.

The M300 Series system has the following key functions and features:

- IP connectivity to simplify installation and system integration.
- 6 simultaneous video outputs, including 2 visible and 2 thermal digital streams. For further information, refer to the following section: [p.41 — Video connections](#)
- Pan and tilt operations via dedicated joystick control unit, multifunction display (MFD), or Web browser.
- 2 axis mechanical camera stabilization to suit changing conditions.
- Preset modes (Scenes) optimized for prevailing conditions.

- Color Thermal Vision (CTV) blending mode — blends thermal and visible light color video feeds for enhanced identification of buoys, vessels and other targets at night.
- Multi Spectral Dynamic Imaging (MSX) blending mode — adds specific details from the visible video feed in real time to the thermal video feed, for detecting and sharpening the edges of objects in the thermal video feed.
- Marine Video Analytics (MVA) — intelligent thermal analytics technology; provides visual alerts when “non-water” objects are identified in the scene. This feature can be enabled using the camera’s Web interface or the on-screen display via a connected JCU.
- Automatic window heaters to de-ice the lens window in cold conditions.
- 12 V or 24 V dc power.

### 3.2 System overview

The camera has a flexible array of connection options to enable you to integrate it with your electronics system.

With the right combination of devices and connections, you can view and control the camera’s image from the most convenient locations on your vessel.

The following illustration shows a very **typical** installation scenario. For more system configuration examples, ranging from small to large systems, refer to: [p.47 — Network connections](#)

For an overview of the camera’s video connection options, refer to: [p.40 — Video connections](#)

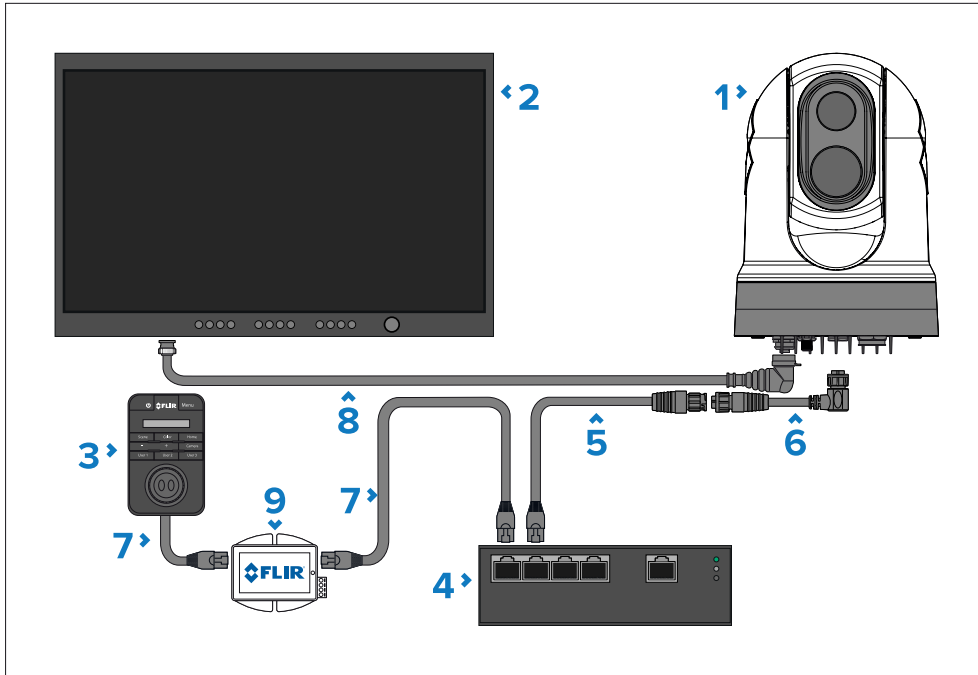

Item	Description
7	RJ45 to RJ45 cable, available separately
8	HD-SDI video cable (BNC connectors) (3 m / 9.8 ft.) (supplied with camera)
9	PoE injector (provides power to JCU-2), available separately

**Note:**

Power connections are not shown in this illustration. The camera, display and Ethernet network switch require their own dedicated power connections. The JCU-2 is powered via Power over Ethernet (PoE), using an optional PoE injector.

Item	Description
1	M300 Series camera
2	Digital video (HD-SDI) monitor, available separately from third-party retailers
3	Joystick control unit (JCU-2), available separately
4	Ethernet network switch (available separately)
5	RayNet (Ethernet) to RJ45 adapter cable (120 mm / 4.7 in.) (supplied with camera)
6	Right-angled RayNet (Ethernet) to RayNet (Ethernet) cable 3 m (9.8 ft.)

### 3.3 Control options

The following illustration shows the different options available for controlling the camera.

These options are not exclusive; the camera can be controlled from more than one device.

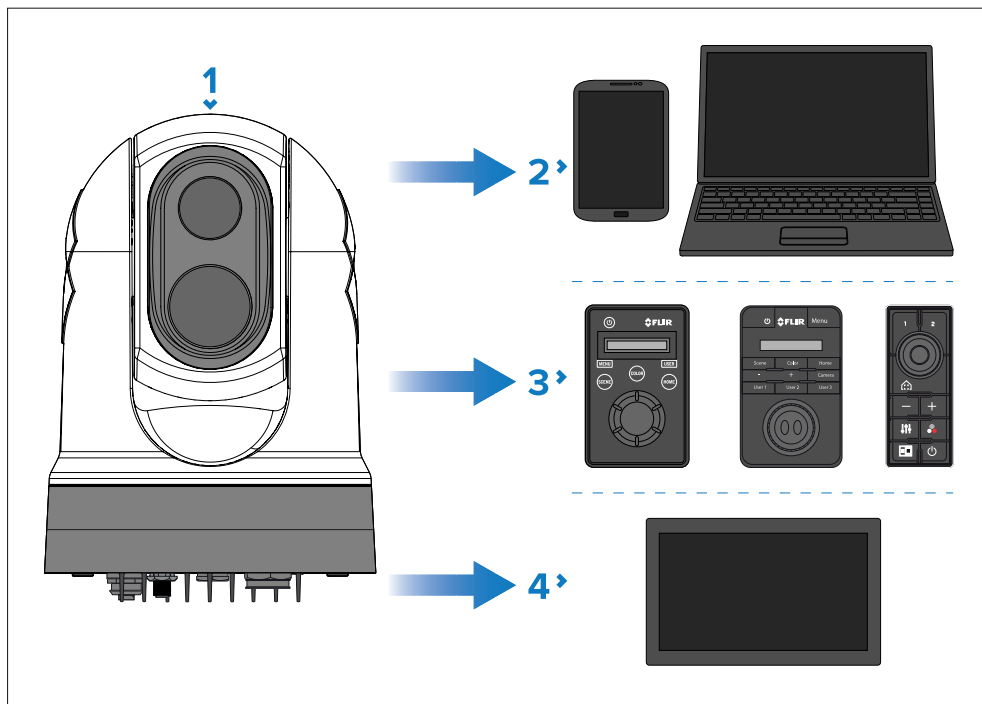

#### Note:

This illustration does NOT include any cables or accessories that may be required to connect the products shown; it is simply an overview of control options. For more information on specific connections, refer to the *Connections* section.

1. Camera.
2. Laptop or another Ethernet device running a Web browser, via an Ethernet connection.
3. JCU-1 / JCU-2 / JCU-3, via an Ethernet connection.
4. Compatible multifunction display, via an Ethernet connection.

### 3.4 Display options

The following illustration shows the different options available for displaying the camera's digital and analog video feeds.

**All video feeds are available simultaneously.**

For more information on the different video feeds available and their respective video formats, refer to: [p.40 — Video connections](#)

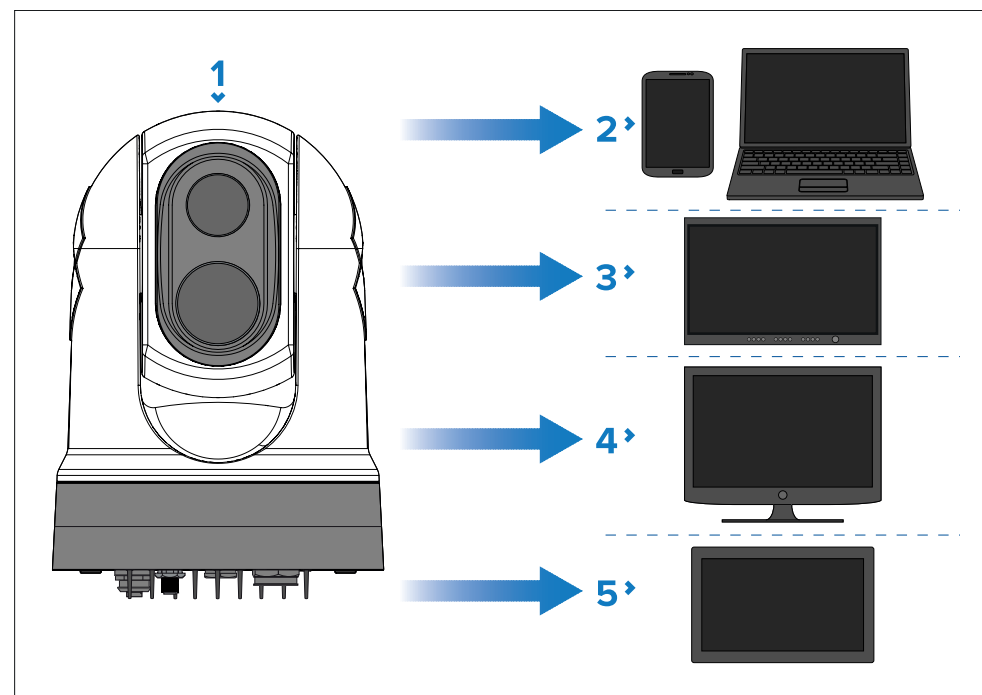

#### Note:

This illustration does NOT include any cables or accessories that may be required to connect the products shown. For more information on specific connections, refer to the *Connections* section.

1. Camera.
2. Laptop or another Ethernet device running a Web browser: via an Ethernet connection.

3. Digital video monitor: via a HD-SDI connection directly to the camera (or a HDMI connection via a converter, available separately from third-party retailers).
4. Analog video monitor: via a composite analog video connection available on the camera's power cable.
5. Compatible multifunction display: via an Ethernet connection.

**Note:**

This product is ONVIF compatible and uses Profile S.

### 3.5 Multicasting

Multicasting is a method of transmitting a stream of data (e.g. an IP video feed) from a single source (e.g. thermal camera) to multiple destinations (e.g. video displays) on a network, eliminating the need for the stream to be transmitted individually from the source to each destination device.

Multicasting is effective at optimizing bandwidth in systems where multiple users on the same network require access to the same live IP video stream. With multicasting, the network bandwidth remains the same between the camera and the core of the network, even as the number of destination devices increases. This reduces the traffic strain on network infrastructure, and makes it easier to plan and manage predictable bandwidth requirements.

However, multicasting is not suitable for all systems, and there are a number of important considerations to make before implementing multicasting in your network:

- Multicasting is often only required in large systems featuring multiple receivers of the IP video stream(s). For smaller networks consisting of up to 2 or 3 displays receiving the IP video stream, unicast may be the preferred option, due to the added complexity of configuring and managing multicast networks.
- Multicasting is only possible when ALL network devices receiving the multicast stream (switches, routers, displays, etc) are also multicast compatible and enabled. Refer to the documentation which accompanies your network devices for multicast compatibility information and additional configuration instructions.
- When using multicasting, your network must be capable of managing multiple transmission methods within the same network (i.e. multicast and unicast). This is because IP video sources may not always transmit

identically, and certain devices in a network may not necessarily support multicasting.

### 3.6 Enabling multicasting

In order to enable the *[multicast]* setting, you must first setup and log in to the Web browser user interface, by following the instructions found in the following section: [p.68 — Camera operation via Web browser](#)

With the Web browser user interface displayed:

1. Navigate to: *[Video > Enable Multicast]*.
2. Select *[Yes]*.

### 3.7 Compatible joystick controllers (JCU)

A joystick control unit (JCU) is available to purchase as an optional accessory. This enables you to control the camera remotely.



JCU variant	More information & manuals
JCU-1 (500-0385-00)	
JCU-2 (500-0398-10)	<a href="http://www.flir.com/products/jcu2/">www.flir.com/products/jcu2/</a>
JCU-3 (A80510)	<a href="http://www.flir.com/products/jcu3/">www.flir.com/products/jcu3/</a>

## 3.8 Compatible multifunction displays

Some multifunction displays (MFDs) may support camera control options via an ONVIF (Profile S) compatible video / camera application. The range of control options available will be dependent on the support that the MFD manufacturer has developed for the dedicated video / camera application. Refer to your MFD manufacturer for information on whether your display is compatible with the camera.

The image streamed via the camera's RayNet (Ethernet) connector can also be viewed on any MFD featuring a Web browser. The on-screen controls displayed in the Web browser will enable you to perform basic camera control operations from your MFD, including pan / tilt functions and setting menu changes.

### **Note:**

It is recommended that you use a dedicated video / camera application in order to:

- View an improved camera video feed quality (via the H.264 video codec).
- Avoid Web browser session expiration.

# CHAPTER 4: PARTS SUPPLIED

## CHAPTER CONTENTS

- 4.1 Parts supplied — page 25

## 4.1 Parts supplied

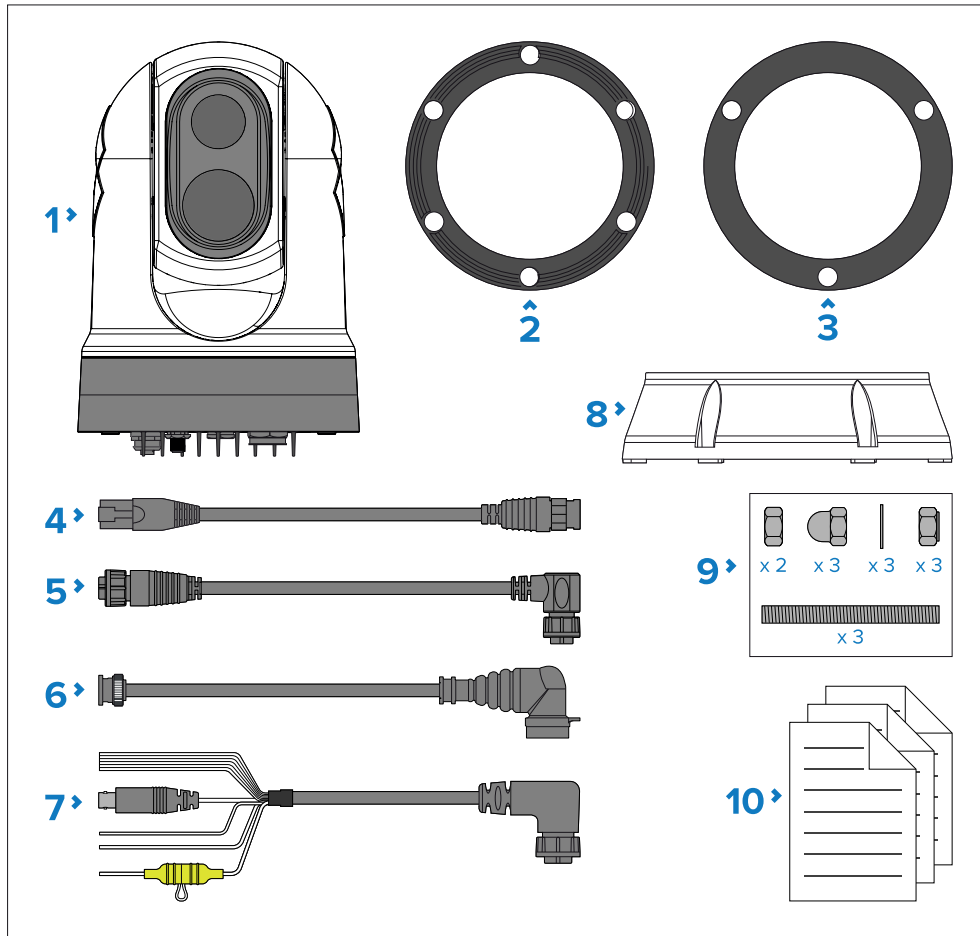

Item	Description
5	Right-angled RayNet (Ethernet) to RayNet (Ethernet) cable 3 m (9.8 ft.)
6	Right-angled HD-SDI video cable (with BNC connectors) 3 m (9.8 ft.)
7	Right-angled power/NMEA 0183/video cable 3 m (9.8 ft.)
8	Mounting riser
9	Fixings: 3x M6 dome nuts, 3x M6 threaded studs, 3x M6 spring washers, 3x M6 nyloc nuts, and 2x M6 flat washers
10	Documentation

Item	Description
1	M300 Camera
2	Riser base-seal
3	Camera seal
4	RayNet (Ethernet) to RJ45 adapter cable 120 mm (4.72 in.)

# CHAPTER 5: PRODUCT DIMENSIONS

## CHAPTER CONTENTS

- [5.1 Product dimensions — page 27](#)

## 5.1 Product dimensions

### M300 Series

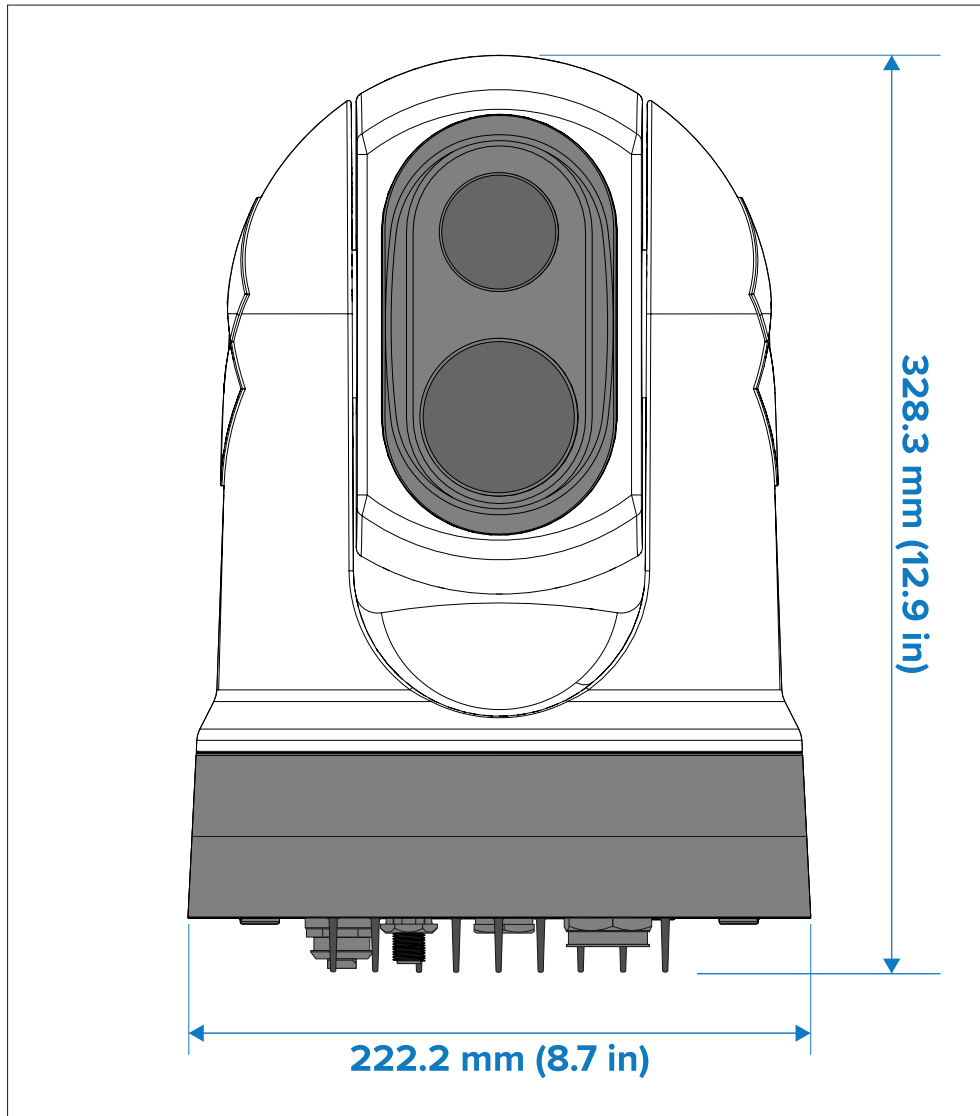

### M300 Series with optional mounting riser

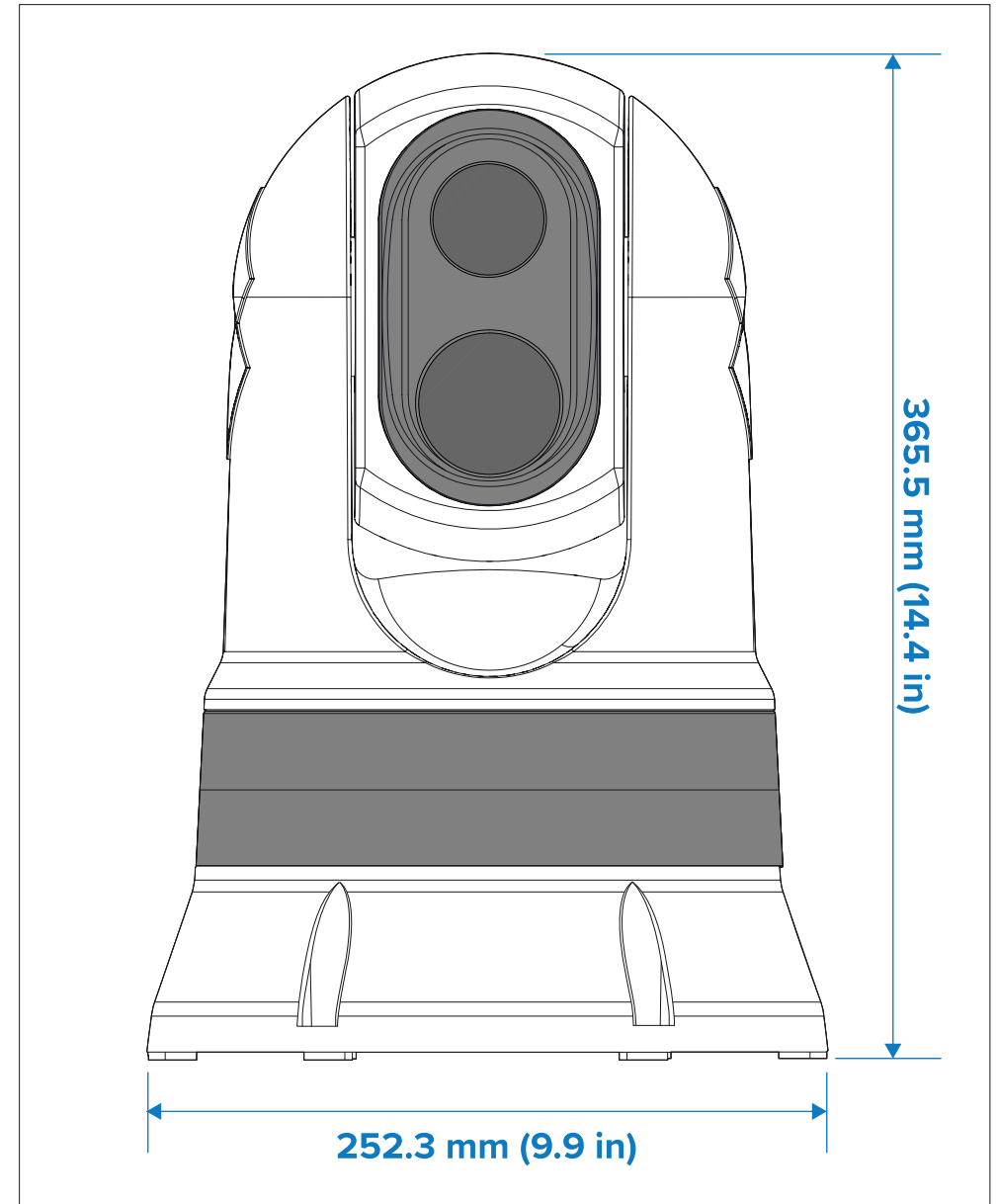

**Note:**

Base diameter with riser base-seal fitted is 254 mm (10 in).

**Mounting riser**

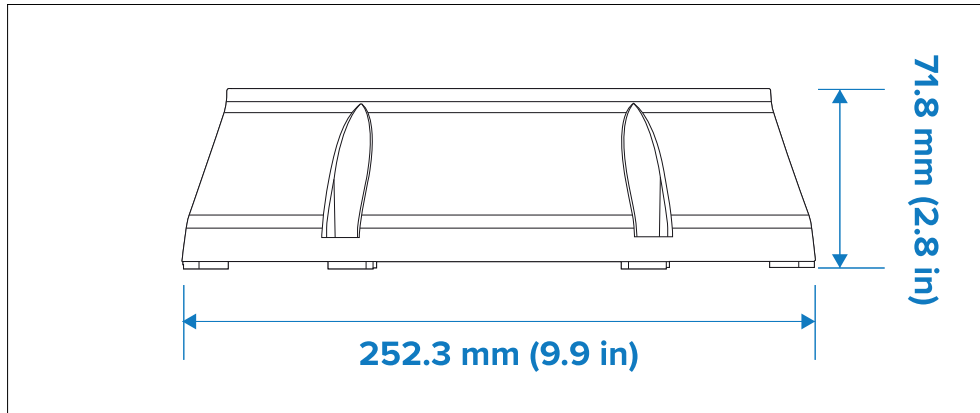

# CHAPTER 6: LOCATION REQUIREMENTS

## CHAPTER CONTENTS

- 6.1 General location requirements — page 30
- 6.2 Location requirements — Camera — page 30

## 6.1 General location requirements

Important considerations when choosing a suitable location for your product.

The product should be mounted where it will be:

- Protected from physical damage and excessive vibration.
- Well ventilated and away from heat sources.

When choosing a location for the product, consider the following points to ensure reliable and trouble-free operation:

- **Access** — there must be sufficient space to enable cable connections to the product, avoiding tight bends in the cable.
- **Center line** — the product should be mounted as close to your vessel's central line as possible to provide a symmetrical view of all angles.

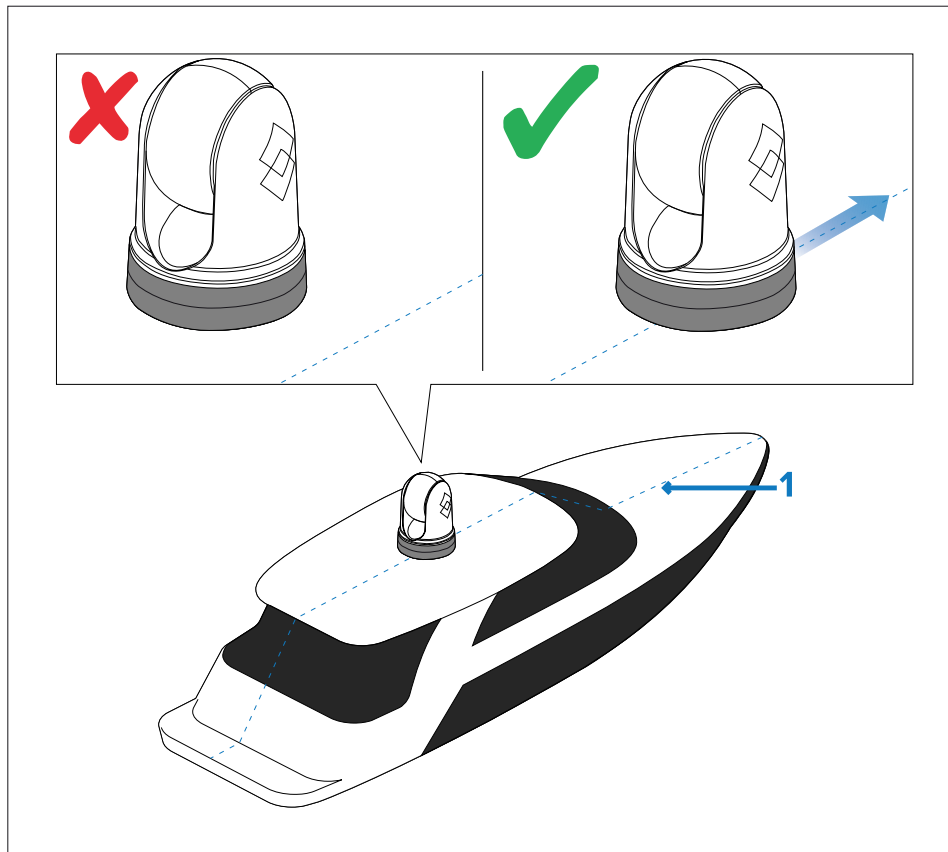

1. Vessel's center line.

- **Clear view** — the product should have a clear view of the water with minimal obstruction to the 360° view.
- **Electrical interference** — the product should be mounted far enough away from any equipment that may cause interference such as motors, generators and radio transmitters / receivers.
- **Magnetic compass** — refer to the *Compass safe distance* section in this document for advice on maintaining a suitable distance between this product and any compasses on your vessel.
- **Height** — the product should be mounted as high as practical, giving a clear view of all directions.
- **Power** — to keep cable runs to a minimum, the product must be located as close as possible to the vessel's dc power supply.
- **Mounting surface** — ensure the product is adequately supported on a secure surface. Refer to the weight information provided in the *Technical specification* for this product and ensure that the intended mounting surface is suitable for bearing the product weight. Do NOT mount units or cut holes in places which may damage the structure of the vessel.

### Compass safe distance

To prevent potential interference with the vessel's magnetic compasses, ensure an adequate distance is maintained from the product.

When choosing a suitable location for the product you should aim to maintain the maximum possible distance from any compasses. Typically this distance should be at least 1 m (3.3 ft) in all directions. However for some smaller vessels it may not be possible to locate the product this far away from a compass. In this situation, when choosing the installation location for your product, ensure that the compass is not affected by the product when it is in a powered state.

## 6.2 Location requirements — Camera

When planning the installation location, consider the following points:

- The camera is waterproof, and appropriate for above decks mounting.
- When mounting the camera in a ball-down position, ensure that the camera is installed with adequate drainage so that standing water does not collect in the base.

- Ensure the camera is installed in a location that will allow it to be accessed for regular periodic cleaning (fresh-water rinse), inspection of mounting point integrity and mechanical soundness, and preventative maintenance.
- The underside (inside) of the compartment or deck on to which the camera is mounted must be weather-tight. You must ensure protection from water ingress to cables and connections.
- The mounting surface must be horizontal.
- If you cannot access both sides of the mounting surface, then you will need to mount the camera “top down” using the mounting riser supplied with the camera.
- The camera should be mounted as high as practical, but without interfering with any radar, navigational or communications electronics.
- Choose a location that will provide the most unobstructed view in all directions.
- Choose a location as close to the vessel’s center line as possible. This provides a symmetrical view when looking forward or aft.
- Select a location for the camera that is at least 1 m (3.3 ft) from any magnetic compass.
- Select a location that is at least 1 m (3.3 ft) from devices that may cause interference, such as motors, generators and radio transmitters / receivers.
- If installing an optional JCU, select a location for the JCU that is at least 1 m (3.3 ft) from any magnetic compass.

**Note:**

If you want to make cable connections to the camera before mounting it to your vessel (for example, to test the camera), first attach the three threaded studs to the base, see: [p.35 — Mounting the camera](#)

This will help to protect the cable connectors on the base of the camera, and also provides a stable platform, helping to prevent damage caused by the unit rolling off the edge of the work surface.

# CHAPTER 7: MOUNTING

## CHAPTER CONTENTS

- 7.1 Tools required — page 33
- 7.2 Camera orientation — page 33
- 7.3 Camera mounting — page 34

## 7.1 Tools required

The following tools are required for installation.

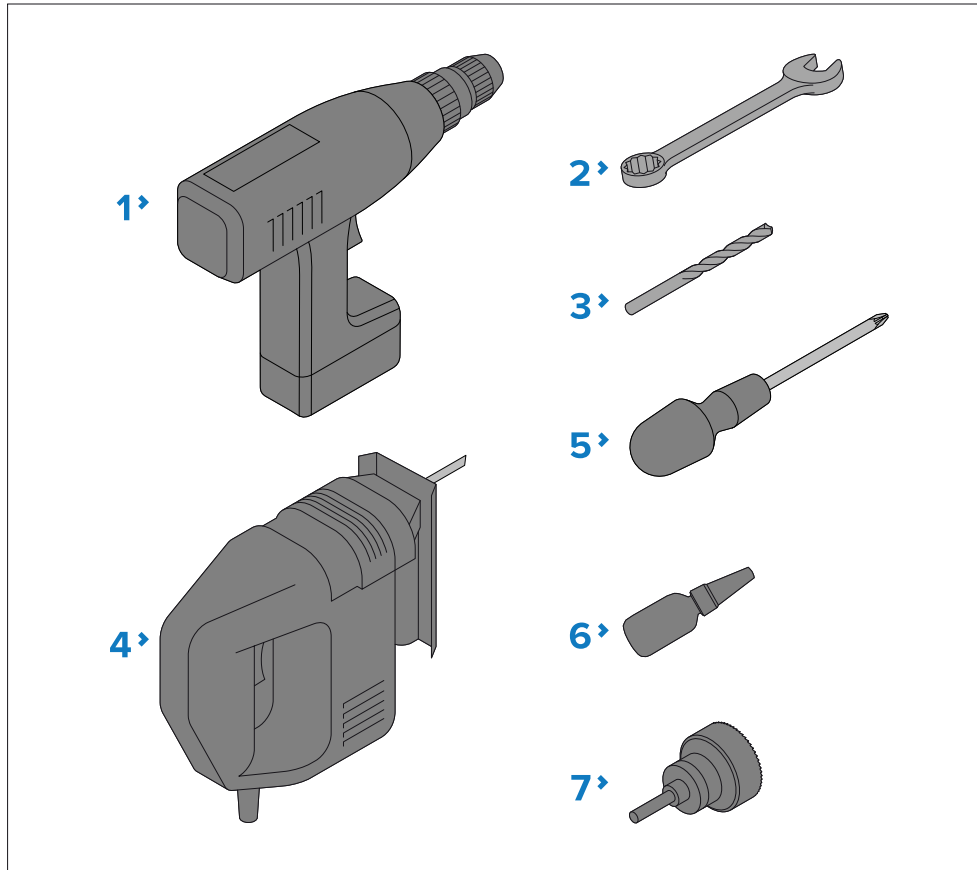

1. Drill
2. 10 mm (0.39 in.) spanner
3. Drill bit (appropriate size dependent on thickness and material of mounting surface)
4. Jigsaw
5. Pozi-drive screwdriver
6. Thread-lock
7. 50 mm (2 in.) Hole saw

Mounting

## 7.2 Camera orientation

The camera can be mounted in 2 orientations informally known as “Ball-up” (upright) and “Ball-down” (upside down).

### Ball-up (upright)

The camera is mounted on top of the mounting surface.

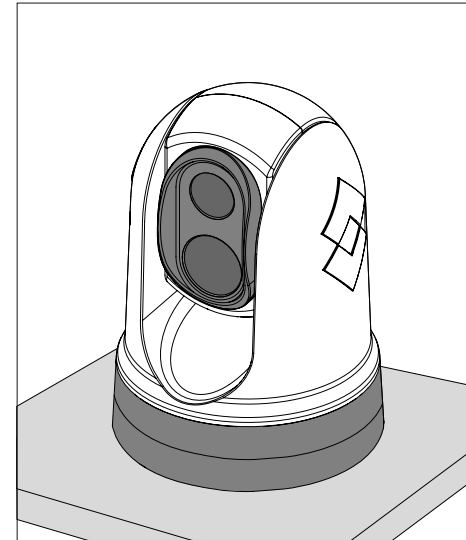

### Ball-down (upside down)

The camera is suspended upside down, below the mounting surface.

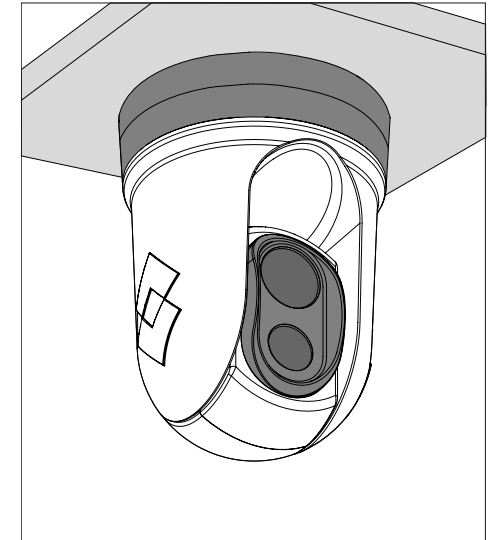

The default video image orientation is for the ball-up (upright) configuration; if the camera is to be mounted in the ball-down (upside down) configuration then the video image must be rotated. To rotate the video image, you must **either**:

- Use the camera’s Web browser user interface to set the appropriate option. For further information, refer to the following section: [p.68 — Camera operation via Web browser](#)
- Use an ONVIF supported MFD video application to set the appropriate option. For further information, refer to documentation which accompanies your display.

## Ball-down (upside down) mounting: rotating the front cover

If you intend to mount your camera in the ball-down (upside down) mode, you must first rotate the camera's front cover so that the drain hole is facing down when it is mounted.

1. Unscrew the rear cover screw.
2. Remove the rear cover.
3. Unscrew the 4 front cover screws and spring washers.
4. Remove the front cover and rotate it 180° so that the drain hole is facing down when the camera is mounted.
5. Reassemble the front cover with the screws and spring washers. The screws must be tightened to a torque of 0.8 N·m (0.6 lbf·ft).
6. Screw the back cover on.

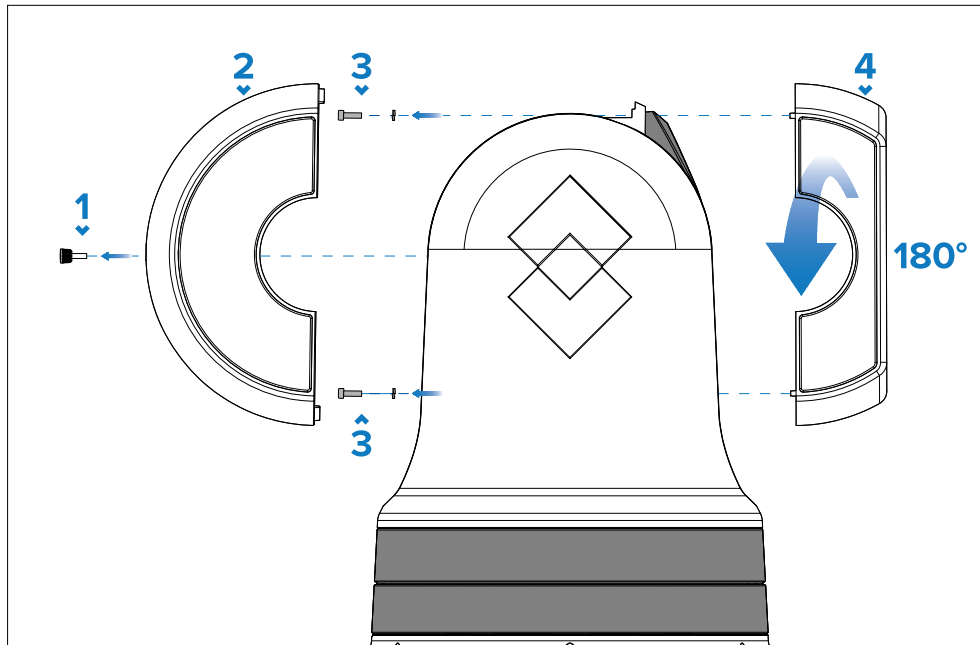

## 7.3 Camera mounting

### Inserting the studs into the camera base

The supplied threaded studs are provided pre-coated with threadlocker. You may need to use the supplied flat nuts to assist you in winding the studs into the camera base.

#### Important:

If the supplied threaded studs are not long enough to accommodate all the fixings and the thickness of the mounting surface, obtain longer replacement **marine-grade stainless steel M6** threaded studs (e.g. 316/A4), and apply a suitable threadlocker (e.g. "Loctite 243"), to all studs. Once the studs are inserted, clean any excess threadlocker from the studs and base, and then allow the threadlocker to cure for 24 hours before proceeding with the installation.

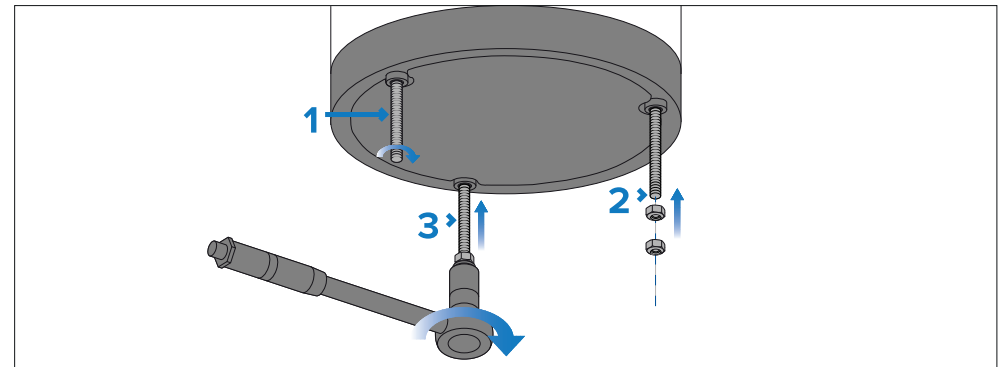

1. Insert the stud into the camera base by hand, with just enough turns to prevent it falling out.
2. Fit the 2 supplied flat nuts to the end of the stud, with just enough turns to secure the nuts.
3. Using an M6 socket wrench or spanner, securely grip the lower flat nut and then wind the studs fully into the camera base mounting holes.
4. Once the studs are fully inserted into the camera base, remove and discard the flat nuts.

## Mounting the camera

Use these instructions to mount the camera unit to your preferred mounting position.

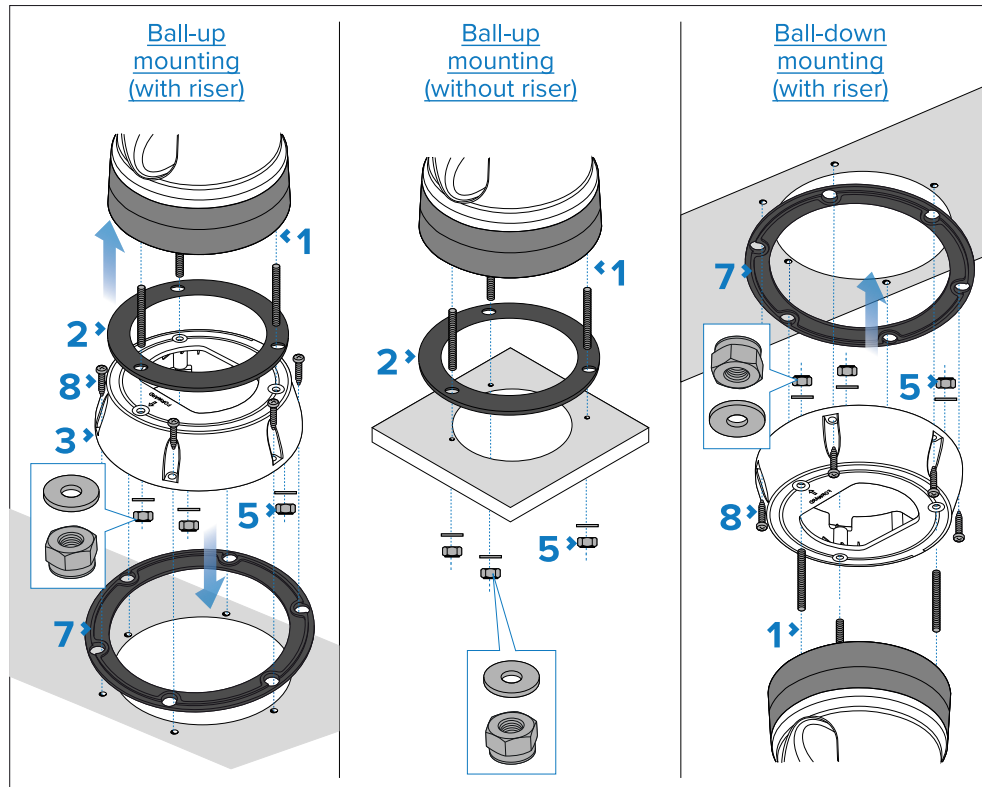

1. Use the supplied mounting template to drill the holes for the camera base (or riser, if used), and the cables.
2. Place the camera seal on the bottom of the camera, carefully aligning the seal holes with the threaded studs.

### Note:

If you are mounting the camera in the ball-down (upside down) position, do NOT fit the camera seal between the camera and the riser.

3. Optionally, (temporarily) secure the riser to the camera with a few hand turns of the nyloc nuts on the studs, to prevent the riser from falling while

you connect the cables. Check that the camera seal remains firmly in place.

### Note:

Observe the camera forward marking on the top surface of the riser. You must ensure that the riser is mounted so that the camera is oriented properly, relative to the vessel's bow.

4. Connect the cables to the camera. If using the riser, loop the cables round within the riser base so that they can be threaded through the bottom of the riser, and into the cable routing hole drilled in the mounting surface.
5. Secure the camera assembly to the mounting surface (or riser, if used), using the supplied flat washers and nyloc nuts. Pay careful attention to the correct arrangement of the fixings, as shown in the image above.

### Note:

If you are replacing an existing camera installation or have purchased an older riser, do NOT use the existing spring washers supplied with the camera or riser.

6. **Tighten the nyloc nuts to a torque of 5.0 - 6.0 N·m (3.7 - 4.4 lbf·ft).**
7. Fit the supplied riser base-seal to the riser.
8. Secure the riser to the mounting surface using screws suitable for the mounting surface material and thickness. (Fixings not supplied).

# CHAPTER 8: CONNECTIONS OVERVIEW

## CHAPTER CONTENTS

- 8.1 Connections overview — page 37
- 8.2 General cabling guidance — page 38

## 8.1 Connections overview

Physical connectors available on the camera, and suitable connections and cables.

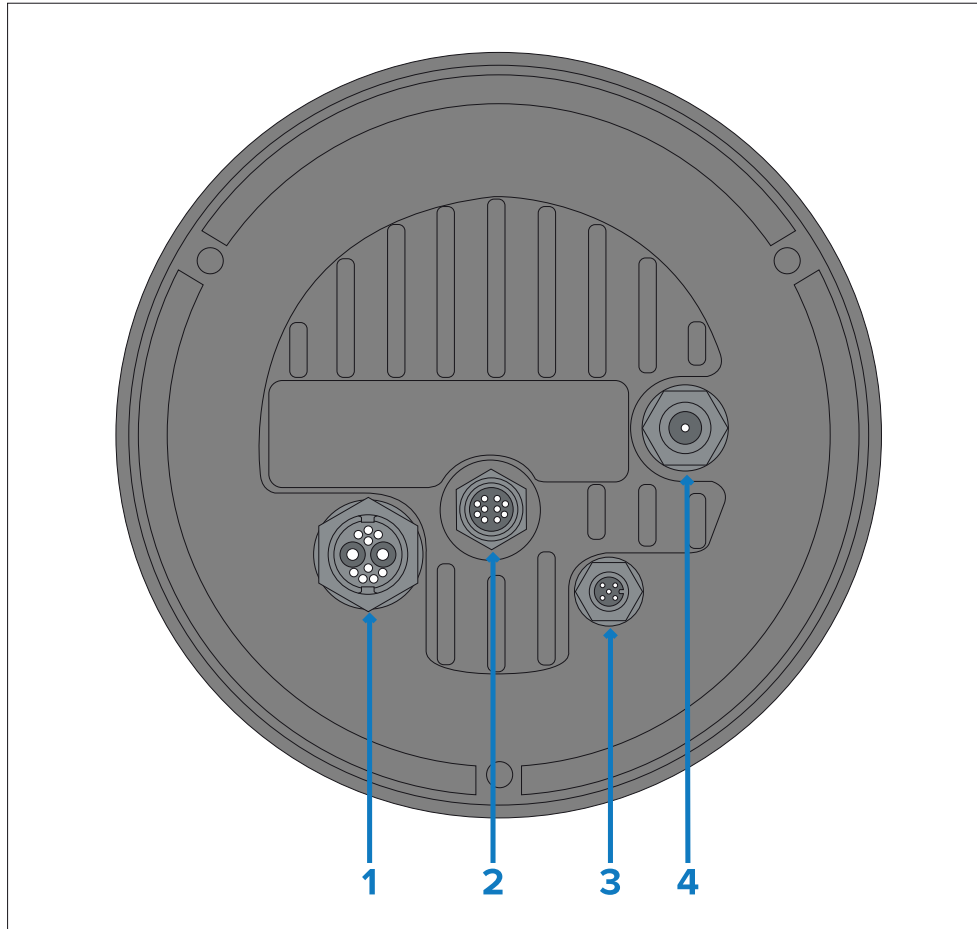

Connector	Suitable cables
1) Power / NMEA 0183 / Composite video Connects to: <ul style="list-style-type: none"><li>• 12 / 24 V dc power supply</li><li>• NMEA 0183 in / out</li><li>• Composite video (on female BNC connector)</li></ul>	<ul style="list-style-type: none"><li>• Right-angled power supply cable (supplied)</li></ul>
2) RayNet (Ethernet) Connects to: <ul style="list-style-type: none"><li>• RayNet (Ethernet) network device</li></ul>	<ul style="list-style-type: none"><li>• RayNet (Ethernet) to RJ45 adapter cable (supplied)</li><li>• Right-angled RayNet (Ethernet) to RayNet (Ethernet) cable (supplied)</li></ul>
3) <u>DeviceNet</u> <b>This connection is not currently supported.</b>	Not applicable — this connection is not currently supported.
4) HD SDI Connects to: <ul style="list-style-type: none"><li>• HD-SDI digital video device. Alternatively, the camera can be connected to an HDMI device via suitable converter and adapter cables, available separately from third-party retailers.</li></ul>	<ul style="list-style-type: none"><li>• HD-SDI video cable (supplied), terminated in BNC connectors.</li></ul>

For more information on available cables refer to [p.104 — Spares and Accessories](#)

### Note:

The cables should be routed to a dry area of the vessel for connection. Alternatively you must ensure that all connections are water tight.

**Note:**

If you want to make cable connections to the camera before mounting it to your vessel (for example, to test the camera), first attach the 3 threaded studs to the base. This will help to protect the cable connectors on the base of the camera, and also provides a stable platform, helping to prevent damage caused by the unit rolling off the edge of the work surface.

## Connecting cables

Follow the steps below to connect the cable(s) to your product.

1. Ensure that the vessel's power supply is switched off.
2. Ensure that the device being connected has been installed in accordance with the installation instructions supplied with that device.
3. Ensuring correct orientation, push cable connectors fully onto the corresponding connectors.
4. Engage any locking mechanism to ensure a secure connection (e.g.: turn locking collars clockwise until tight, or in the locked position).
5. Ensure any bare ended wire connections are suitably insulated to prevent shorting and corrosion due to water ingress.

## Orientation of right-angled connectors

When making connections using the supplied right-angled power and network cables, ensure that you orient the connectors correctly with respect to the thermal camera base.

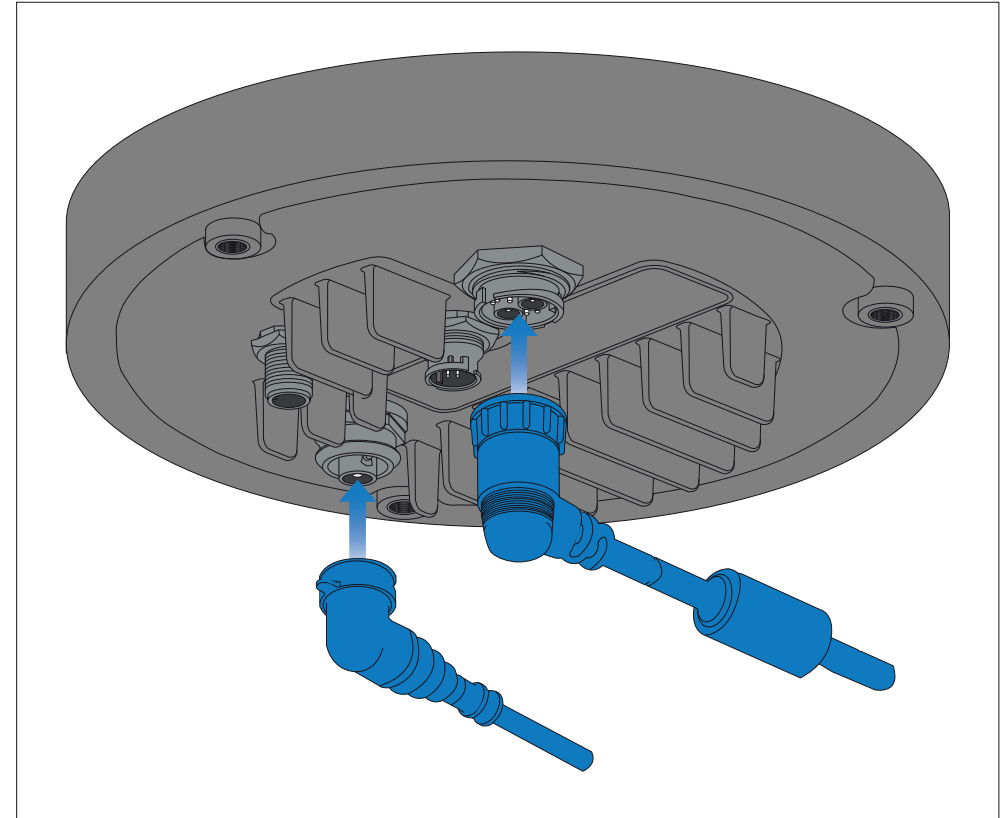

## 8.2 General cabling guidance

### Cable types and length

It is important to use cables of the appropriate type and length.

- Unless otherwise stated use only standard cables of the correct type, supplied by FLIR.

- Ensure that any non-FLIR cables are of the correct quality and gauge. For example, longer power cable runs may require larger wire gauges to minimize voltage drop along the run.

## Cable routing

Cables must be routed correctly, to maximize performance and prolong cable life.

- Do NOT bend cables excessively. Wherever possible, ensure a minimum bend diameter ( $\emptyset$ ) of 200 mm (7.87 in) / minimum bend radius (R) of 100 mm (3.94 in).

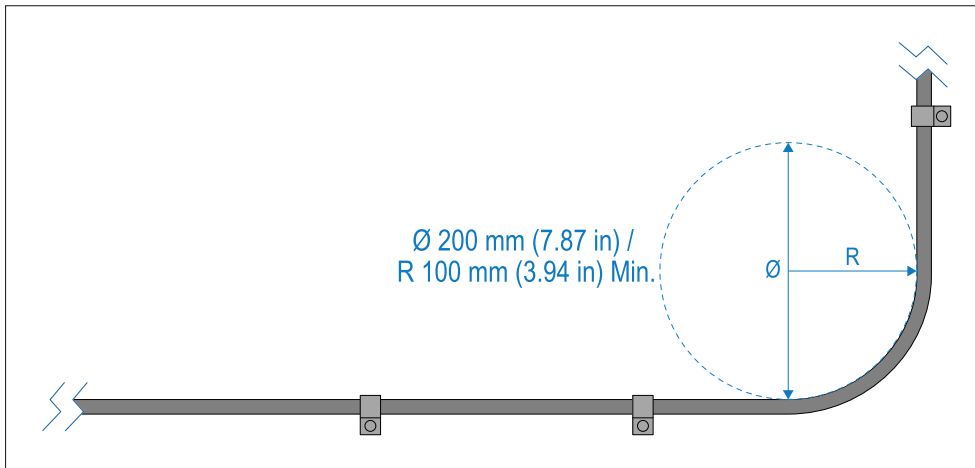

- Protect all cables from physical damage and exposure to heat. Use trunking or conduit where possible. Do NOT run cables through bilges or doorways, or close to moving or hot objects.
- Secure cables in place using cable clips or cable ties. Coil any excess cable and tie it out of the way.
- Where a cable passes through an exposed bulkhead or deckhead, use a suitable watertight feed-through.
- Do NOT run cables near to engines or fluorescent lights.
- Always route data cables as far away as possible from:
  - Other equipment and cables.
  - High current carrying AC and DC power lines.
  - Antennas.

## Strain relief

Use adequate strain relief for cabling to ensure that connectors are protected from strain and will not pull out under extreme sea conditions.

## Circuit isolation

Appropriate circuit isolation is required for installations using both AC and DC current:

- Always use isolating transformers or a separate power-inverter to run PC's, processors, displays and other sensitive electronic instruments or devices.
- Always use an isolating transformer with Weather FAX audio cables.
- Always use an isolated power supply when using a 3rd party audio amplifier.
- Always use an RS232/NMEA converter with optical isolation on the signal lines.
- Always make sure that PC's or other sensitive electronic devices have a dedicated power circuit.

## Cable shielding

Ensure that cable shielding is not damaged during installation and that all cables are properly shielded.

# CHAPTER 9: VIDEO CONNECTIONS

## CHAPTER CONTENTS

- 9.1 Video connections — page 41

## 9.1 Video connections

The camera supports multiple video formats, and is capable of providing different video feeds to multiple devices, simultaneously.

Furthermore, with the dual payload camera variants you can use a **combination** of different video connection methods to display both thermal and visible video feeds simultaneously. For example, you can view the thermal video feed via a display connected to the camera's HD-SDI connector, and the visible video feed at the same time, via a display connected to the camera's RayNet (Ethernet) connector.

The different camera video output methods are described below:

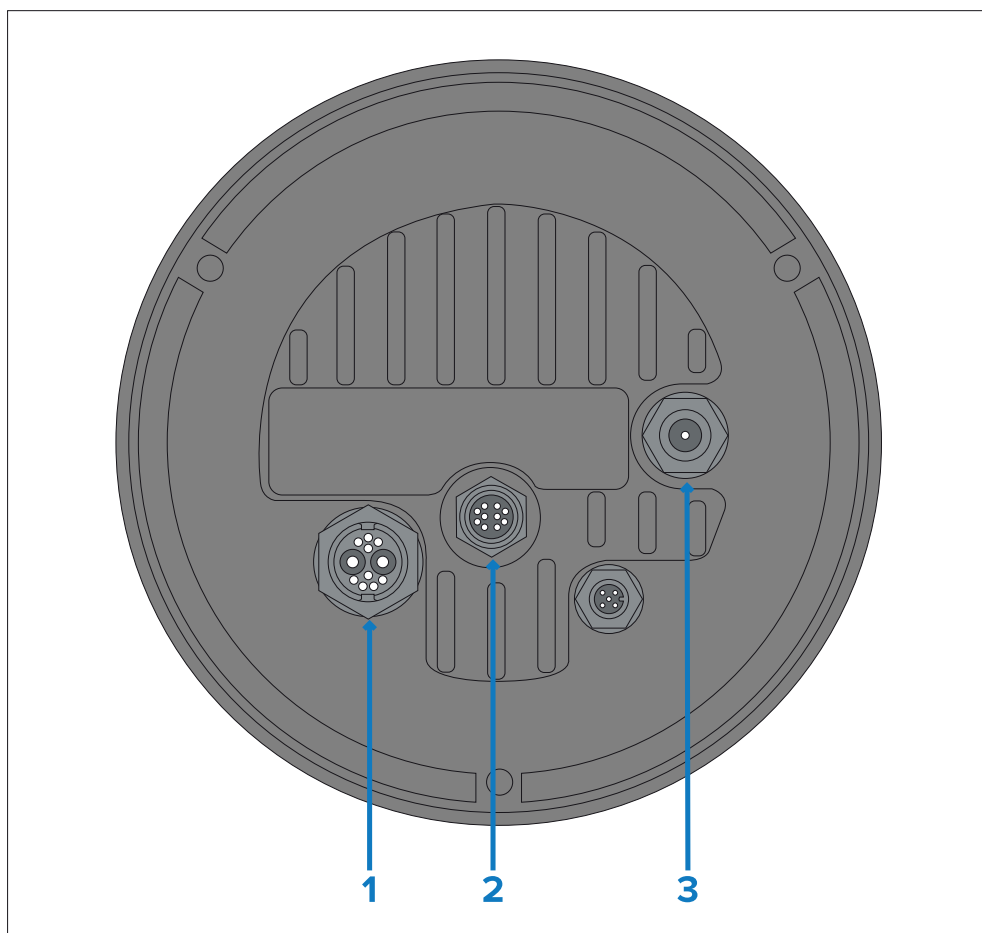

### Connector

### Video format

#### 1) Composite video BNC connector on camera's power cable

Analog PAL / NTSC composite video — on dual-payload cameras, this video feed is user-selectable between visible and thermal.

#### 2) RayNet (Ethernet)

Primary digital IP video streams:

- For single payload cameras, one primary thermal or visible video feed is available at full HD resolution (1920 x 1080).
- For dual payload cameras, 2 primary thermal and/or visible video feeds are available at full HD resolution (1920 x 1080).

#### Supported codecs:

- **H264-encoded digital video stream** — offers an improved camera video feed quality over MJPEG and is streamed to an ONVIF (Profile S)-compatible IP video-capable device.
- **MJPEG-encoded digital video stream** — offers a lower latency time over H.264 and is streamed to a Web browser on a PC / laptop / tablet.

#### Supported resolutions:

- 1920 x 1080
- 1280 x 720
- 960 x 540
- 854 x 480
- 640 x 360

**Supported protocols:** ONVIF (Profile S) or RTSP

Connector	Video format
<p><b>2) RayNet (Ethernet)</b></p> <p>Secondary digital IP video streams:</p> <p>Secondary streams are available in addition to, and at the same time as, primary streams.</p> <p>Depending on your chosen camera model, secondary streams can be any combination of thermal and/or visible video feeds.</p> <ul style="list-style-type: none"> <li>For single payload cameras, one secondary thermal or visible video feed is available at a 1280 x 720 resolution.</li> <li>For dual payload cameras, 2 secondary thermal and/or visible video feeds are available at a 1280 x 720 resolution in addition to, and at the same time as the 2 primary video feeds.</li> </ul>	<p><b>Supported codecs:</b></p> <ul style="list-style-type: none"> <li><b>H264-encoded digital video stream</b> — this is streamed to an ONVIF (Profile S)-compatible IP video-capable device.</li> <li><b>MJPEG-encoded digital video stream</b> — this is streamed to a Web browser on a PC / laptop / tablet.</li> </ul> <p><b>Supported resolutions:</b></p> <ul style="list-style-type: none"> <li>1280 x 720</li> <li>960 x 540</li> <li>854 x 480</li> <li>640 x 360</li> </ul> <p><b>Supported protocols:</b></p> <ul style="list-style-type: none"> <li>ONVIF (Profile S)</li> <li>RTSP</li> </ul>
<p><b>3) HD-SDI</b></p>	<p>Digital video, HD-SDI format (SMPTE-292M).</p>

### Important:

When streaming digital IP video to multiple devices via the RayNet (Ethernet) connector and a network switch, it may be necessary to set the *[Enable Multicast]* option to “Yes”, in the *Camera Settings* menu. Multicasting is very effective at optimizing bandwidth in systems where multiple users on the same network require access to the same live IP video stream. The default setting for the camera is “No” (i.e. only Unicast video streams), which means that the stream can only be received by a limited number of IP devices (typically less than 3). For more information, refer to: [p.54 — Multicasting](#)

### Note:

It is also possible to connect to an HDMI-capable display or device, via a suitable third-party HD-SDI to HDMI converter.

- The MD-HX HDMI / (3G/HD/SD)-SDI Cross Converter is not suitable for use due to unreliable performance.

Contact your dealer or retailer for suitable devices and cables.

### Note:

ONVIF profiles help you to determine which IP digital video devices are compatible with one another. For more information on ONVIF profiles, refer to: [www.onvif.org/profiles/](http://www.onvif.org/profiles/)

## Video and network cables

A range of cables is supplied with the camera to cover typical connection scenarios. You may need to purchase additional cables to complete your installation.

Connector	Suitable cables
Composite video BNC connector on camera's power cable	Use the supplied BNC-to-BNC video cable (3 m / 9.8 ft.), if not using otherwise for the HD-SDI connection. Alternatively, obtain a 75-ohm coax video cable terminated in BNC connectors at both ends. (The BNC connector on the camera's power cable is a female connector).
RayNet (Ethernet)	<b>To connect to a device with an RJ45 socket:</b> Use the supplied RayNet (Ethernet) to RJ45 adapter cable (120 mm / 4.7 in.). Longer adapter cables are available separately.
HD-SDI	Use the supplied BNC-to-BNC video cable (3 m / 9.8 ft.). If a longer cable is required, obtain a 75-ohm coax video cable terminated in BNC connectors at both ends. (The BNC connector on the camera is a female connector).

### Note:

It is also possible to connect to an HDMI-capable display or other video device, via a suitable third-party HD-SDI to HDMI converter. Contact your dealer or retailer for suitable devices and cables.

## HD-SDI cable connection

When making the HD-SDI connection to the camera using the supplied cable, ensure that the rubber shroud surrounding the cable connector is secured with cable ties (not supplied), once fitted to the connector. Fit one tie to the shroud at the point where the cable enters the bottom of the shroud, and another tie around the shroud where it covers the connector itself.

# CHAPTER 10: NMEA 0183 CONNECTION

## CHAPTER CONTENTS

- 10.1 NMEA 0183 connection — page 45
- 10.2 NMEA 0183 overview — page 45
- 10.3 Enabling NMEA features — page 46

## 10.1 NMEA 0183 connection

NMEA 0183 devices can be connected to your camera using the NMEA 0183 wires on the supplied Power/Video/NMEA 0183 cable.

2 NMEA 0183 ports are available:

- **Port 1:** Input and output: 4,800 baud rate only.
- **Port 2:** Input only: 4,800 baud rate only.

### Note:

- For Port 1, both the input and output communicate at the same baud rate. For example, if you have one NMEA 0183 device connected to Port 1 INPUT, and another NMEA 0183 device connected to Port 1 OUTPUT, both NMEA devices must use the same baud rate.

Up to 4 devices can be connected to the camera's output port, and up to 2 devices to the camera's input ports.

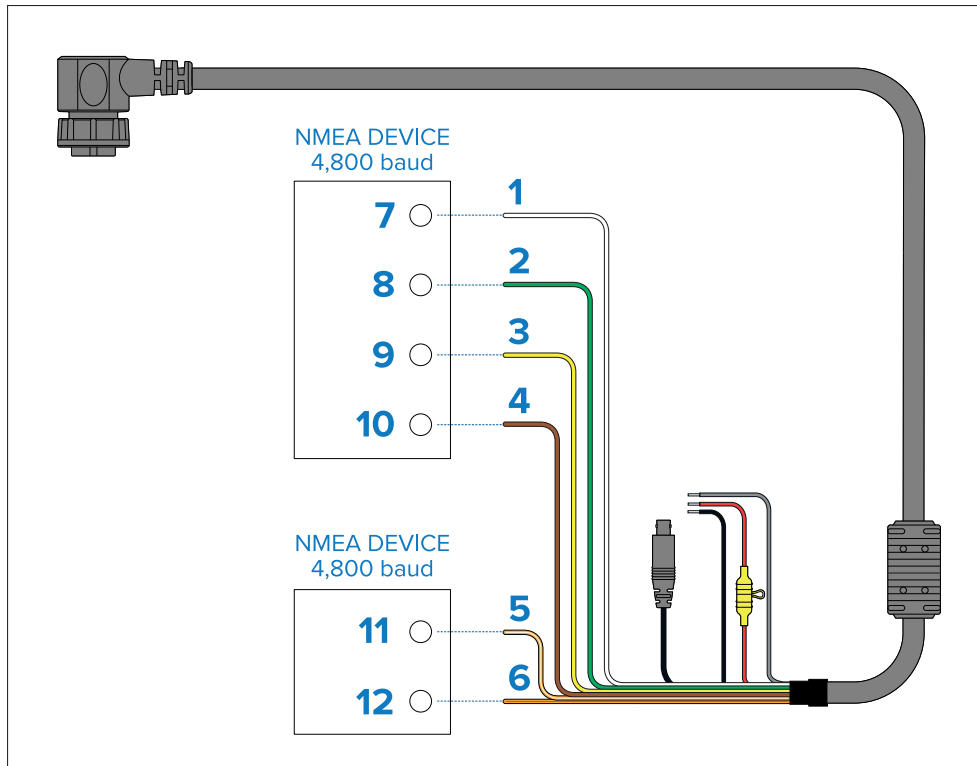

Item	Device	Cable color	Port	Input / output	Positive (+) / negative (-)
1	Camera	White	1	Input	Positive
2		Green	1	Input	Negative
3		Yellow	1	Output	Positive
4		Brown	1	Output	Negative
5		Orange / White	2	Input	Positive
6		Orange / Green	2	Input	Negative
7	NMEA device	*	*	Output	Positive
8		*	*	Output	Negative
9		*	*	Input	Positive
10		*	*	Input	Negative
11	NMEA device	*	*	Output	Positive
12		*	*	Output	Negative

### Note:

\* Refer to instructions provided with your NMEA 0183 device for connection details.

## 10.2 NMEA 0183 overview

The NMEA interface allows the camera to communicate with radar, GPS, or other third-party devices using the National Marine Electronics Association (NMEA) 0183 protocol. NMEA 0183 (or NMEA for short) is a combined electrical and data specification for communication between marine electronic devices.

For information on how to connect NMEA 0183 devices to the camera, refer to: [p.45 — NMEA 0183 connection](#)

For additional information regarding the NMEA 0183 protocol refer to: <https://www.nmea.org/content>

The NMEA 0183 protocol allows the camera to automatically point itself towards vessels and other objects in its field of view, and to track their movement. The camera can receive 3 types of NMEA messages:

- **Radar Cursor Tracking**, which is implemented using the NMEA Radar System Data (**RSD**) sentence.
- **Slew to Waypoint**, which uses the NMEA Bearing and Distance to Waypoint, Great Circle (**BWC**) sentence.
- **Radar Tracking**, which uses the NMEA Tracked Target Message (**TTM**) sentence.

#### Note:

Even though you can only choose three types of messages to enable through the NMEA interface, the cameras use additional messages to perform the calculations needed to respond to these three. If your system is not responding as expected, verify that the NMEA device sending messages is sending the following additional message types:

- HDT (Heading — True)
- GGA (Global Positioning System Fix Data)
- VHW (Water Speed and Heading)
- OSD (Own Ship Data)
- TLL (Target Latitude and Longitude)

#### Note:

Any combination or all 3 of these NMEA messages can be enabled; when more than one type is enabled, the system processes **RSD** first, then **BWC**, and finally **TTM**. For example, if the unit is listening to **BWC** or **TTM** messages and looking at a particular target and it receives an **RSD** message, it waits until the end of the dwell time and then moves on to the **RSD** message, ignoring all other input.

#### Important:

In order for the NMEA features to work correctly, the camera's altitude above the waterline must be specified using the camera's Web interface. Enter the altitude by accessing the Web interface and selecting the *[Georeference]* tab.

## 10.3 Enabling NMEA features

For more information on how to enable the various NMEA features (such as Radar integration, for example), refer to: [p.92 — NMEA \(Radar Tracking\)](#)

# CHAPTER 11: NETWORK CONNECTIONS

## CHAPTER CONTENTS

- 11.1 Network connections — page 48
- 11.2 Multicasting — page 54
- 11.3 Enabling multicasting — page 55

## 11.1 Network connections

Your camera has a single RayNet (Ethernet) network connector. This connects the camera to your vessel's wider IP network, such as to an existing Ethernet network.

The details of the network connections between the camera, video display (Web browser, video monitor, or compatible multifunction display), control unit (for example, a JCU-2 controller) and the rest of your installation depend on:

- How you want to control the camera (for example, with a Web browser, a MFD ONVIF compatible video application, a JCU controller, or a combination).
- How you want to view the camera's IP video feed (for example, via a laptop / PC, a compatible multifunction display, or a combination).
- The equipment already installed on your vessel (for example, network switches with free ports, or other cameras).

The following sections show some possible network connections, starting with a basic system with a single camera directly connected to Web browser, and finishing with a more complex multi-camera, multi-display, multi-JCU system.

### Note:

Power connections are not shown throughout each of the following illustrations. For power connection information, refer to the instructions which accompany each device.

### Note:

An Ethernet network switch is only required in the following scenarios when the camera needs to be connected to more than one Ethernet device. For a high speed connection, ensure that equipment is connected to your network switch via an available gigabit port.



### Warning: PoE isolation coupler

Some networks require an inline Power over Ethernet (PoE) isolation coupler to be fitted before the camera can be connected to the network.

The inline PoE isolation coupler may be required regardless of whether a network device (e.g. a multifunction display or network switch) outputs PoE or not.

Before connecting the camera to a network, refer to your network device manufacturer for more information.

### Single-camera system with a compatible MFD and JCU

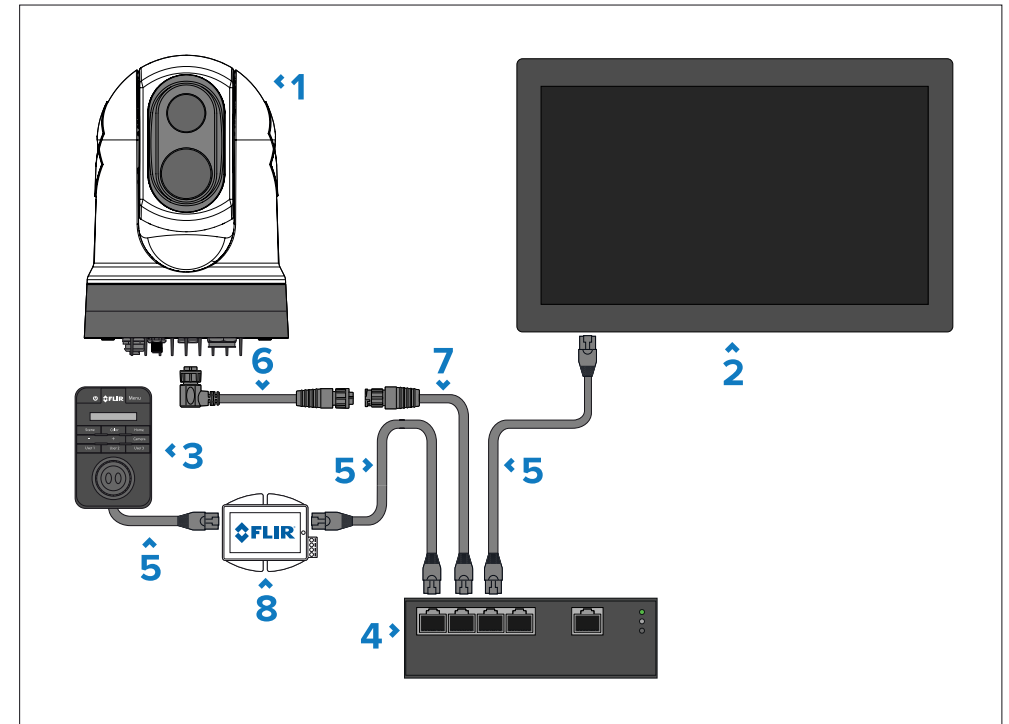

Item	Description
1	M300 Series camera
2	Compatible MFD, available separately

Item	Description
3	Joystick control unit (JCU-2), available separately
4	Ethernet network switch, available separately
5	RJ45 to RJ45 Ethernet cable, available separately
6	Right angled RayNet (Ethernet) to RayNet (Ethernet) cable (3 m / 9.8 ft), 1x supplied with camera
7	RayNet (Ethernet) to RJ45 adapter cable (120 mm / 4.7 in.), 1x supplied with camera
8	PoE injector (provides power to JCU-2), available separately

### Single-camera system with a digital video (HD-SDI) monitor and JCU

For this system, a device running a Web browser is not required. The camera's video feed is routed through the camera's HD-SDI video connection to a digital video monitor. Camera control is provided by a JCU (available separately).

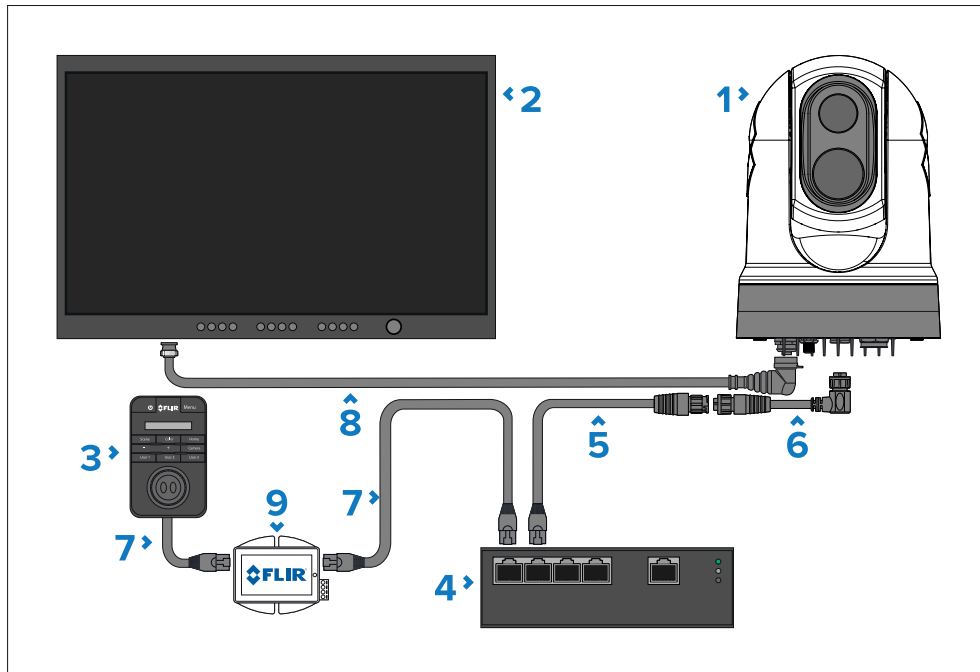

Item	Description
1	M300 Series camera
2	Digital video (HD-SDI) monitor, available separately from third-party retailers
3	Joystick control unit (JCU-2), available separately
4	Ethernet network switch, available separately
5	RayNet (Ethernet) to RJ45 adapter cable (120 mm / 4.7 in.), 1x supplied with camera
6	Right-angled RayNet (Ethernet) to RayNet (Ethernet) cable 3 m (9.8 ft.), 1x supplied with camera
7	RJ45 to RJ45 Ethernet cable, available separately
8	HD-SDI video cable (BNC connectors) (3 m / 9.8 ft.), 1x supplied with camera
9	PoE injector (provides power to JCU-2), available separately

## Single-camera system with a digital video (HDMI) monitor and JCU

For this system, a device running a Web browser is not required. The camera's video feed is routed through the camera's HD-SDI video connection via a third-party HD-SDI to HDMI video converter (not supplied) to a digital video monitor. Camera control is provided by a JCU (available separately).

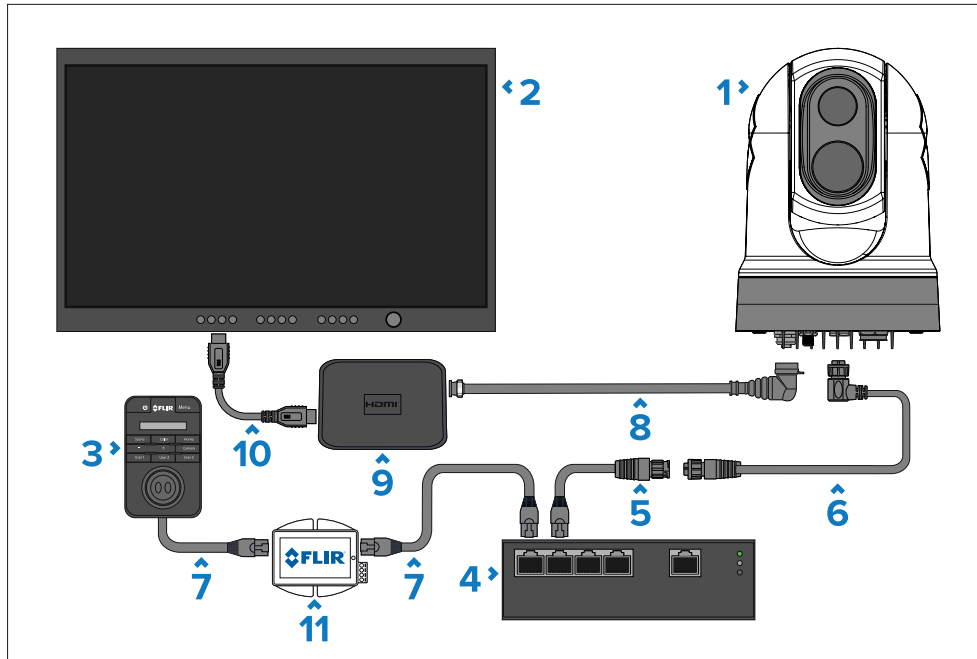

Item	Description
6	Right angled RayNet (Ethernet) to RayNet (Ethernet) cable (3 m / 9.8 ft), 1x supplied with camera
7	RJ45 to RJ45 Ethernet cable, available separately
8	HD-SDI video cable (BNC connectors) (3 m / 9.8 ft.), 1x supplied with camera
9	HD-SDI to HDMI video converter, available separately from third-party retailers
10	HDMI cable, available separately from third-party retailers
11	PoE injector (provides power to JCU-2), available separately

Item	Description
1	M300 Series camera
2	Digital video (HDMI) monitor, available separately from third-party retailers
3	Joystick control unit (JCU-2), available separately
4	Ethernet network switch, available separately
5	RayNet (Ethernet) to RJ45 adapter cable (120 mm / 4.7 in.), 1x supplied with camera

## Single-camera system with an analog video monitor and JCU

For this system, a device running a Web browser is not required. The camera's video feed is routed through the power cable's composite analog video connection to an analog video monitor. Camera control is provided by a JCU (available separately).

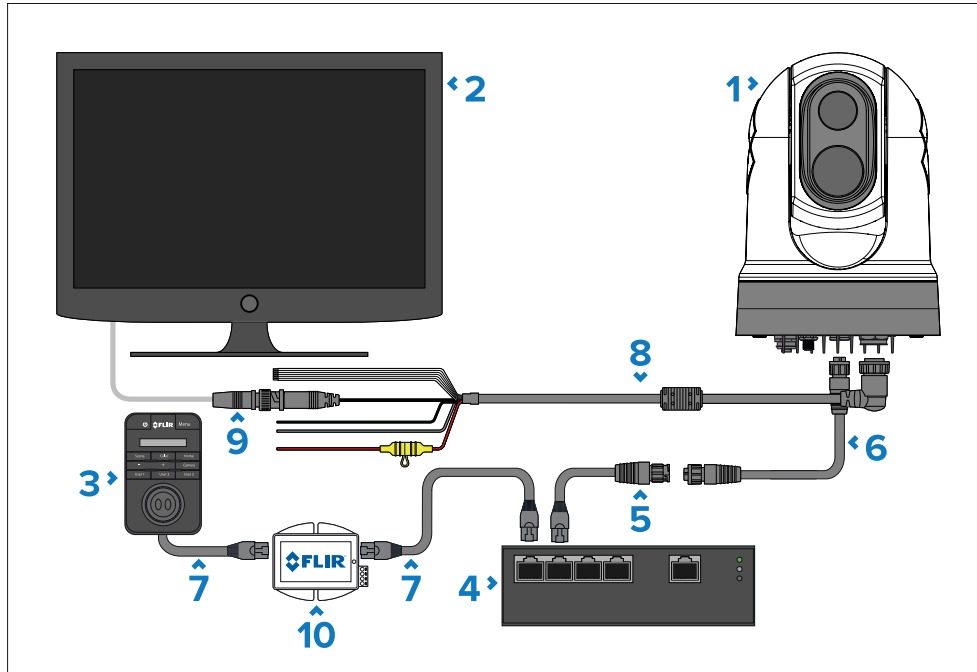

Item	Description
1	M300 Series camera
2	Analog video monitor, available separately from third-party retailers
3	Joystick control unit (JCU-2), available separately
4	Ethernet network switch, available separately
5	RayNet (Ethernet) to RJ45 adapter cable (120 mm / 4.7 in.), 1x supplied with camera
6	RayNet (Ethernet) to RayNet (Ethernet) cable, available separately

Item	Description
7	RJ45 to RJ45 Ethernet cable, available separately
8	Camera's power cable (3 m / 9.8 ft.), 1x supplied with camera
9	BNC to BNC video cable, available separately. If you are not using the supplied BNC cable (3 m / 9.8 ft.) for the HD-SDI connection, you can use it for this composite analog connection. Otherwise, obtain a suitable cable, separately from third-party retailers.
10	PoE injector (provides power to JCU-2), available separately

## Single-camera system connected to a third-party radar with an analog video monitor and JCU

For this system, a device running a Web browser is not required. The camera's video feed is routed through the power cable's composite analog video connection to an analog video monitor. Camera control is provided by a JCU (available separately).

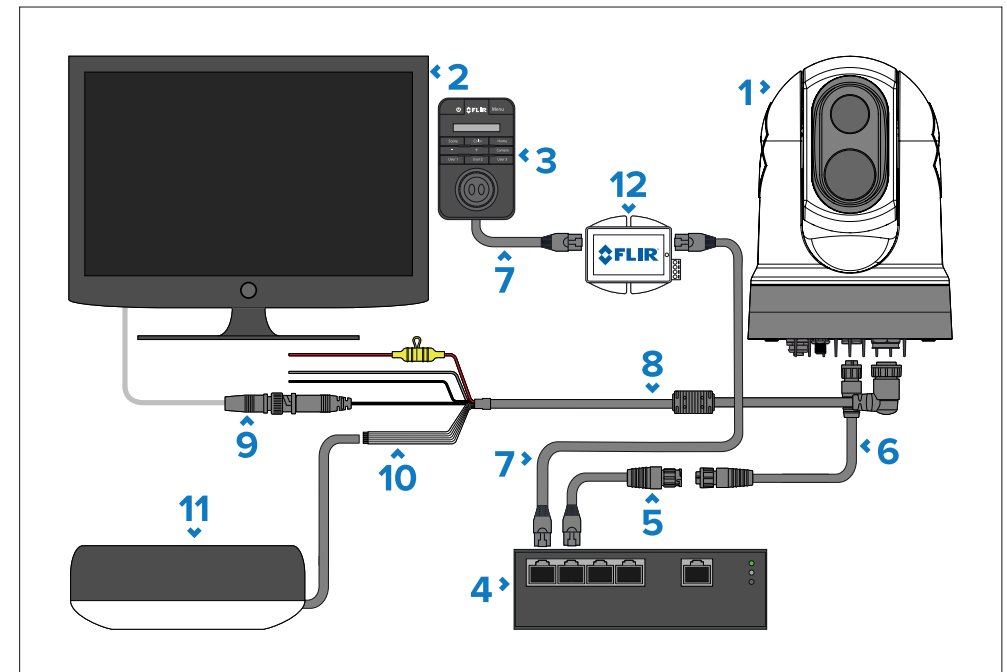

Item	Description
1	M300 Series camera
2	Analog video monitor, available separately from third-party retailers
3	Joystick control unit (JCU-2), available separately
4	Ethernet network switch, available separately
5	RayNet (Ethernet) to RJ45 adapter cable (120 mm / 4.7 in.), 1x supplied with camera
6	RayNet (Ethernet) to RayNet (Ethernet) cable, available separately
7	RJ45 to RJ45 Ethernet cable, available separately
8	Camera's power cable (3 m / 9.8 ft.), 1x supplied with camera
9	BNC to BNC video cable, available separately. If you are not using the supplied BNC cable (3 m / 9.8 ft.) for the HD-SDI connection, you can use it for this composite analog connection. Otherwise, obtain a suitable cable, separately from third-party retailers.
10	NMEA 0183 connection. For information on how to connect NMEA 0183 devices to the camera, refer to: <a href="#">p.45 — NMEA 0183 connection</a>
11	Third-party radar scanner, available separately from third-party retailers
12	PoE injector (provides power to JCU-2), available separately

## Single-camera system with direct connection to a Web browser

The network connection scenario illustrated below is primarily intended for configuration and diagnostic purposes.

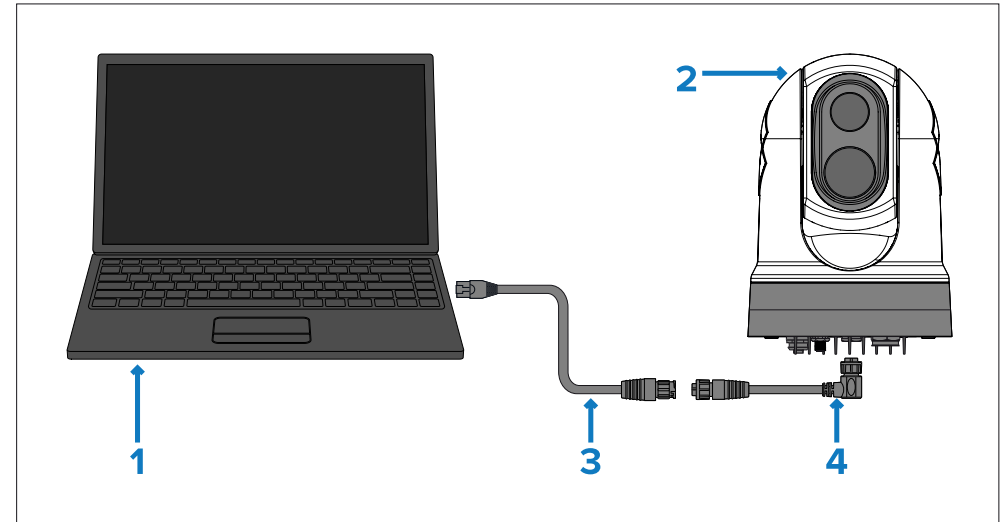

Item	Description
1	Laptop (or another Ethernet-connected device running a Web browser), available separately from third-party retailers
2	M300 Series camera
3	RayNet (Ethernet) to RJ45 adapter cable (120 mm / 4.7 in.), 1x supplied with camera
4	Right angled RayNet (Ethernet) to RayNet (Ethernet) cable (3 m / 9.8 ft), 1x supplied with camera

## Single-camera system with a Web browser and an optional JCU

The network connection scenario illustrated below is primarily intended for configuration and diagnostic purposes.

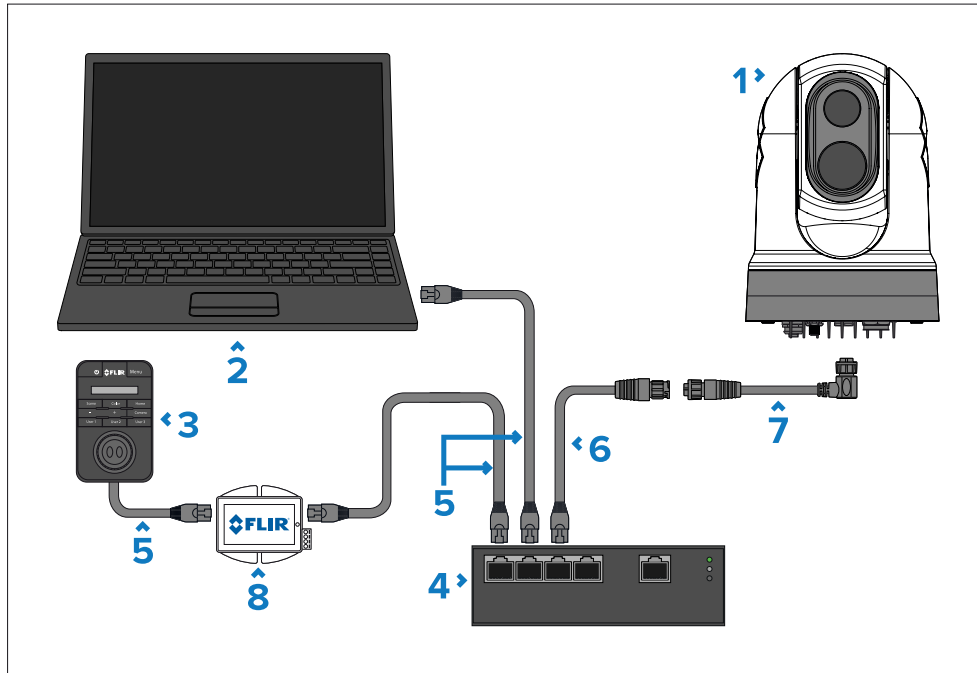

Item	Description
7	Right angled RayNet (Ethernet) to RayNet (Ethernet) cable (3 m / 9.8 ft), 1x supplied with camera
8	PoE injector (provides power to JCU-2), available separately

Item	Description
1	M300 Series camera
2	Laptop (or another Ethernet-connected device running a Web browser), available separately from third-party retailers
3	Joystick control unit (JCU-2), available separately
4	Ethernet network switch, available separately
5	RJ45 to RJ45 Ethernet cable, available separately
6	RayNet (Ethernet) to RJ45 adapter cable (120 mm / 4.7 in.), 1x supplied with camera

## Multi-camera system with a digital video monitor, 2 compatible MFDs, 2 JCUs and a Web browser

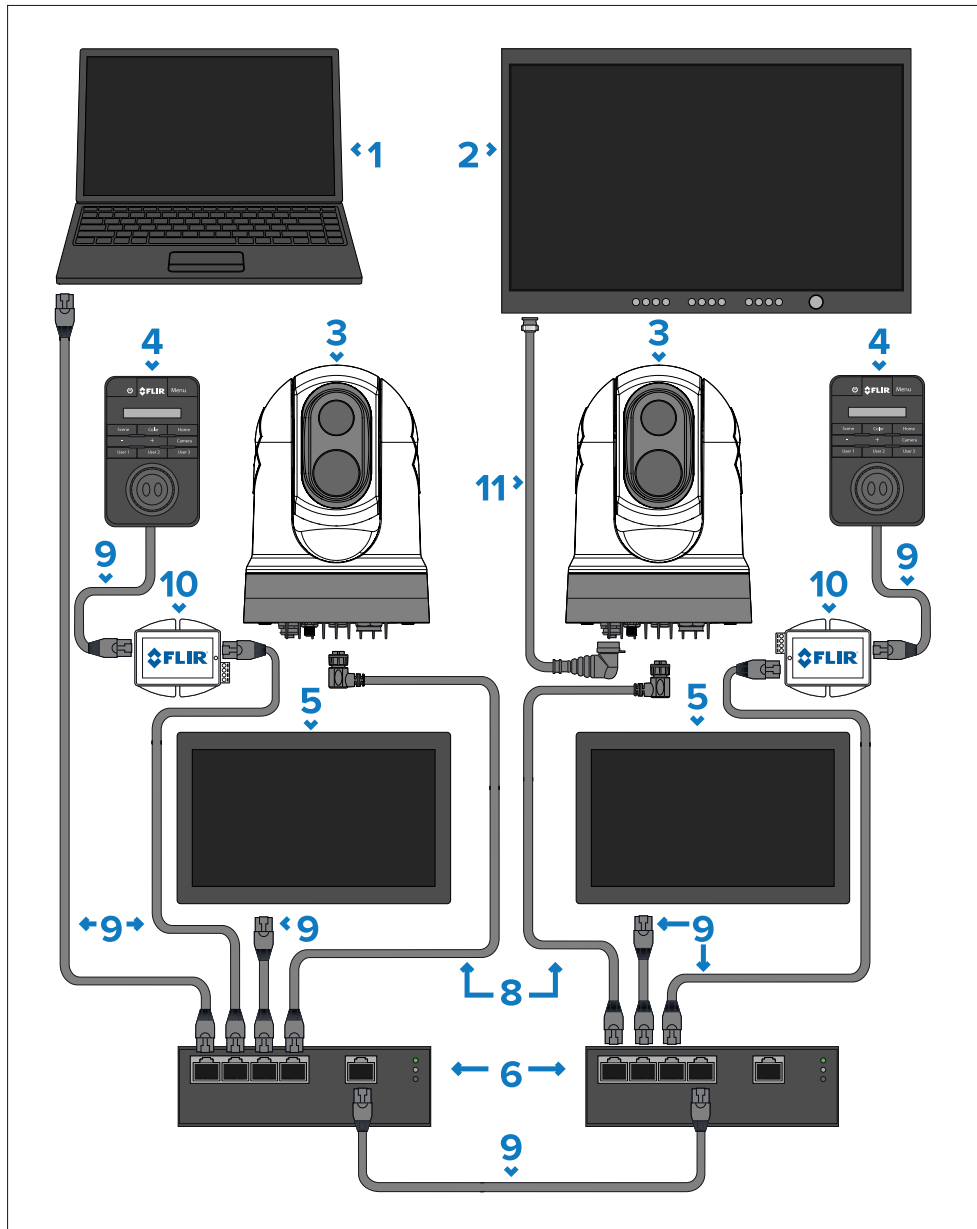

Item	Description
1	Laptop (or another Ethernet-connected device running a Web browser), available separately from third-party retailers
2	Digital video monitor, available separately from third-party retailers
3	M300 Series camera
4	Joystick control unit (JCU-2), available separately
5	Compatible MFD, available separately
6	Ethernet network switch, available separately
7	RayNet to RJ45 cable, available separately
8	Right angled RayNet (Ethernet) to RJ45 cable, available separately
9	RJ45 to RJ45 cable, available separately
10	PoE injector (provides power to JCU-2), available separately
11	HD-SDI video cable (BNC connectors) (3 m / 9.8 ft.), supplied with camera

## 11.2 Multicasting

Multicasting is a method of transmitting a stream of data (e.g. an IP video feed) from a single source (e.g. thermal camera) to multiple destinations (e.g. video displays) on a network, eliminating the need for the stream to be transmitted individually from the source to each destination device.

Multicasting is effective at optimizing bandwidth in systems where multiple users on the same network require access to the same live IP video stream. With multicasting, the network bandwidth remains the same between the camera and the core of the network, even as the number of destination devices increases. This reduces the traffic strain on network infrastructure, and makes it easier to plan and manage predictable bandwidth requirements.

However, multicasting is not suitable for all systems, and there are a number of important considerations to make before implementing multicasting in your network:

- Multicasting is often only required in large systems featuring multiple receivers of the IP video stream(s). For smaller networks consisting of up to 2 or 3 displays receiving the IP video stream, unicast may be the preferred option, due to the added complexity of configuring and managing multicast networks.
- Multicasting is only possible when ALL network devices receiving the multicast stream (switches, routers, displays, etc) are also multicast compatible and enabled. Refer to the documentation which accompanies your network devices for multicast compatibility information and additional configuration instructions.
- When using multicasting, your network must be capable of managing multiple transmission methods within the same network (i.e. multicast and unicast). This is because IP video sources may not always transmit identically, and certain devices in a network may not necessarily support multicasting.

## 11.3 Enabling multicasting

In order to enable the *[multicast]* setting, you must first setup and log in to the Web browser user interface, by following the instructions found in the following section: [p.68 — Camera operation via Web browser](#)

With the Web browser user interface displayed:

1. Navigate to: *[Video > Enable Multicast]*.
2. Select *[Yes]*.

# CHAPTER 12: POWER CONNECTIONS

## CHAPTER CONTENTS

- 12.1 Power connection — page 57

## 12.1 Power connection

Power must be supplied to the camera from an appropriate power source.

### Power connection requirements

- 12 or 24 Vdc nominal supply voltage
- Isolated power supply
- Connected via an appropriately-rated thermal breaker or fused switch (refer to *Inline fuse and thermal breaker ratings*).

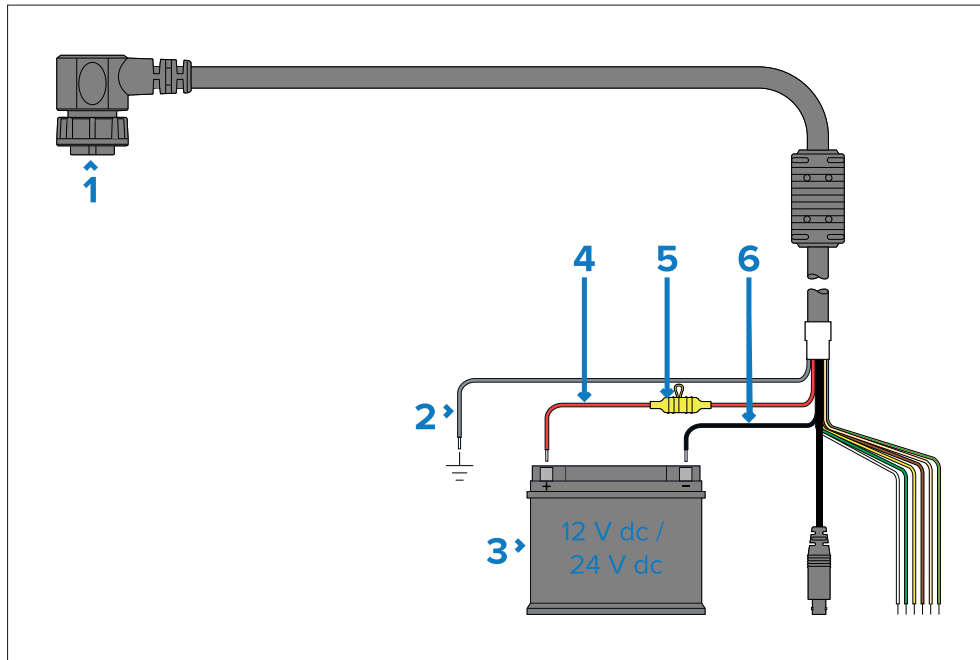

Description	Connects to
1) Power cable	Product's power connector.
2) Drain wire (thin black wire)	Vessel's RF ground, or negative battery terminal.
3) Connection to 12 V / 24 V power supply.	Vessel's power supply.
4) Red cable (positive)	Power supply's positive terminal

Description	Connects to
5) Inline fuse	Waterproof fuse holder containing a suitably-rated inline fuse (refer to <i>Inline fuse and thermal breaker ratings</i> ).
6) Black cable (thick black wire) (negative)	Power supply's negative terminal

### Inline fuse and thermal breaker ratings

The following inline fuse and thermal breaker ratings apply to your product:

Inline fuse rating	Thermal breaker rating
15 A slow blow	15 A (if only connecting one device)

#### Note:

- The suitable fuse rating for the thermal breaker is dependent on the number of devices you are connecting. If in doubt consult an authorized FLIR dealer.

### Power distribution

Recommendations and best practice for the power connection of products supplied with a drain wire as part of the supplied power cable.

- The product is supplied with a power cable, either as a separate item or a captive cable permanently attached to the product. Only use the power cable supplied with the product. Do NOT use a power cable designed for, or supplied with, a different product.
- Refer to the *Power connection* section for more information on how to identify the wires in your product's power cable, and where to connect them.
- See below for more information on implementation for some common power distribution scenarios:

### Important:

- When planning and wiring, take into consideration other products in your system, some of which (e.g. sonar modules) may place large power demand peaks on the vessel's electrical system, which may impact the voltage available to other products during the peaks.
- The information provided below is for guidance only, to help protect your product. It covers common vessel power arrangements, but does NOT cover every scenario. If you are unsure how to provide the correct level of protection, please consult an authorized dealer or a suitably qualified professional marine electrician.

### Implementation — connection to distribution panel (Recommended)

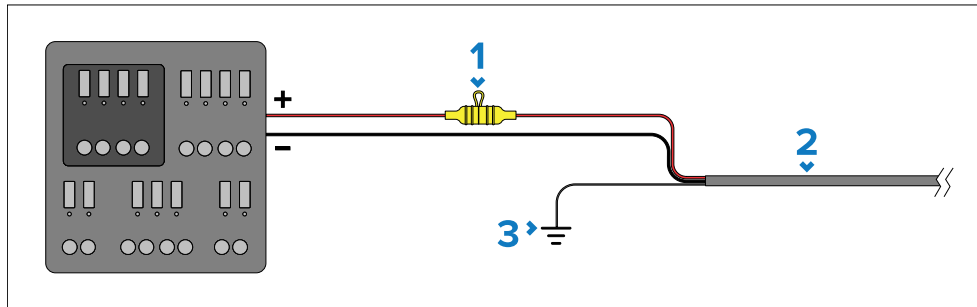

Item	Description
1	Waterproof fuse holder containing a suitably-rated inline fuse must be fitted. For suitable fuse rating, refer to: <i>Inline fuse and thermal breaker ratings</i> .
2	Product power cable.
3	Drain wire connection point.

- It is recommended that the supplied power cable is connected to a suitable breaker or switch on the vessel's distribution panel or factory-fitted power distribution point.
- The distribution point should be fed from the vessel's primary power source by 8 AWG (8.36 mm<sup>2</sup>) cable.
- Ideally, all equipment should be wired to individual suitably-rated thermal breakers or fuses, with appropriate circuit protection. Where this is not possible and more than 1 item of equipment shares a breaker, use

individual inline fuses for each power circuit to provide the necessary protection.

- The power cable supplied with your product includes a drain wire, which must be connected to the vessel's common RF ground.

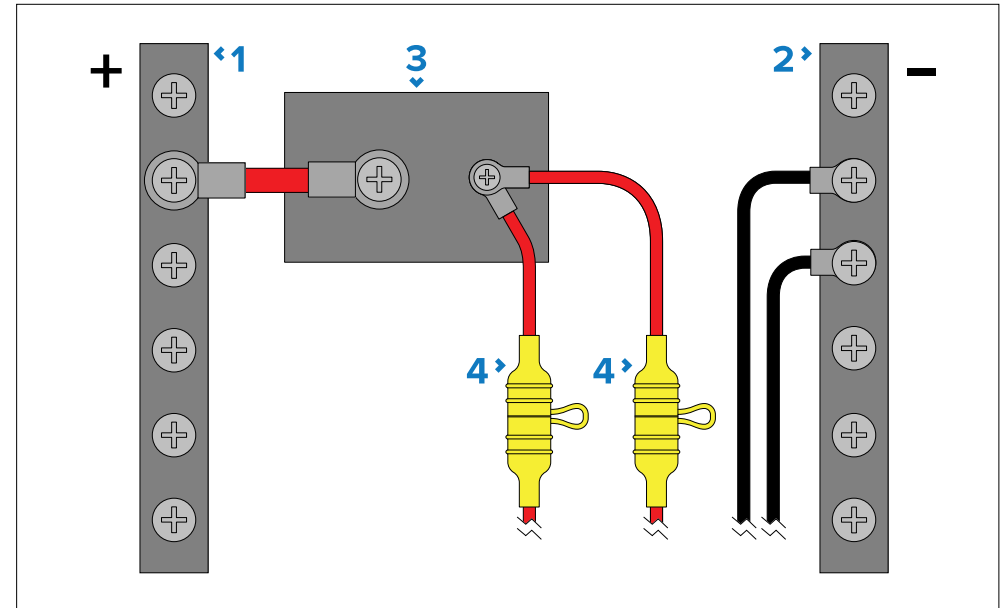

Item	Description
1	Positive (+) bar
2	Negative (-) bar
3	Circuit breaker
4	Waterproof fuse holder containing a suitably-rated inline fuse must be fitted. For suitable fuse rating, refer to: <i>Inline fuse and thermal breaker ratings</i> .

### Important:

Observe the recommended fuse / breaker ratings provided in the product's documentation, however be aware that the suitable fuse / breaker rating is dependent on the number of devices being connected.

## Implementation — direct connection to battery

- Where connection to a power distribution panel is not possible, the power cable supplied with your product may be connected directly to the vessel's battery, via a suitably rated fuse or breaker.
- If the power cable is NOT supplied with a fitted inline fuse, you MUST fit a suitably rated fuse or breaker between the red wire and the battery's positive terminal.
- Refer to the inline fuse ratings provided in the product's documentation.
- If you need to extend the length of the power cable supplied with your product, ensure you observe the dedicated *Power cable extensions* advice provided in the product's documentation.

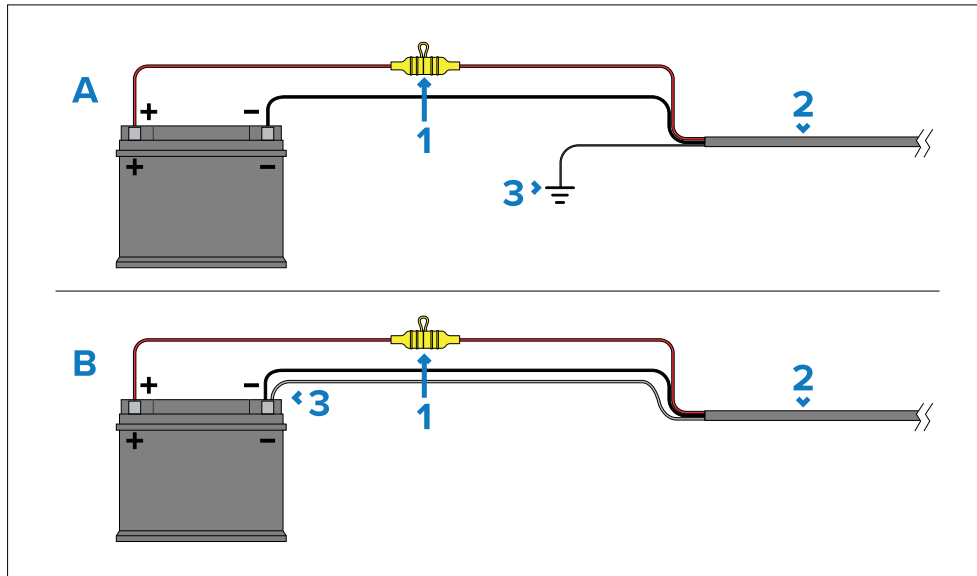

Item	Description
1	Waterproof fuse holder containing a suitably-rated inline fuse must be fitted. For suitable fuse rating, refer to: <i>Inline fuse and thermal breaker ratings</i> .
2	Product power cable.
3	Drain wire connection point.

### Battery connection scenario A:

Suitable for a vessel with a common RF ground point. In this scenario, the power cable's drain wire should be connected to the vessel's common ground point.

### Battery connection scenario B:

Suitable for a vessel without a common grounding point. In this case, the power cable's drain wire should be connected directly to the battery's negative terminal.

## Grounding

Ensure that you observe any additional grounding advice provided in the product's documentation.

## More information

It is recommended that best practice is observed in all vessel electrical installations, as detailed in the following standards:

- BMEA Code of Practice for Electrical and Electronic Installations in Boats
- NMEA 0400 Installation Standard
- ABYC E-11 AC & DC Electrical Systems on Boats
- ABYC A-31 Battery chargers and Inverters
- ABYC TE-4 Lightning Protection

## Power cable drain wire connection

The power cable supplied with this product includes a dedicated drain wire for connection to a vessel's Radio Frequency (RF) ground point (if available), or the negative battery terminal.

It is important that an effective RF ground is connected to the system. A single common ground point should be used for all equipment. If several items require grounding, each item of equipment can be grounded by connecting the drain wire of the power cable first to a single local point (e.g. within a distribution panel), and then this point connected via an appropriately-rated conductor to the vessel's RF common ground point. An RF ground point is typically a circuit with a very low-impedance signal at RF, connected to the sea via an electrode immersed in the sea or bonded to the inner side of the hull in an area that is underwater.

**On vessels without an RF ground system**, the drain wires of all equipment should be connected directly to the vessel's negative battery terminal.

The dc power system should be either:

- Negative grounded (“bonded”), with the negative battery terminal connected to the vessel's RF ground.
- Floating, with neither battery terminal connected to the vessel's ground.

The preferred minimum requirement for the path to ground (bonded or non-bonded) is via a flat tinned copper braid, with a 30 A rating or greater. If this is not possible, an equivalent stranded wire conductor may be used, rated as follows:

- for runs of <1 m (3.3 ft), use 6 mm<sup>2</sup> (10 AWG) or greater.
- for runs of >1 m (3.3 ft), use 8 mm<sup>2</sup> (8 AWG) or greater.

In any grounding system, always keep the length of connecting braid or wires as short as possible.



**Warning: Positive ground systems**

Do not connect this unit to a system which has positive grounding.

# CHAPTER 13: CAMERA CONTROL OPTIONS AND STATUS ICONS

## CHAPTER CONTENTS

- 13.1 Camera control options — page 62
- 13.2 Camera image — page 62
- 13.3 Camera control — page 66

## 13.1 Camera control options

There are a number of different ways of controlling the camera remotely.

- **Via a compatible multifunction display** — With the camera connected to the MFD or the MFD's network via Ethernet, you can either use a Web browser or an ONVIF (Profile S) dedicated video / camera application (if supported by your display) to view and control the camera remotely.
- **Via a Raymarine® LightHouse™ 4 / LightHouse™ 3 multifunction display** — For further information refer to the M300 Thermal Camera Raymarine System Integration guide (81400).
- **Via a JCU** — With the JCU connected to the camera via a network switch, you can use the JCU's physical controls to control the camera remotely.
- **Via a Web browser** — With the camera connected to a laptop or another Ethernet device, you can use the camera's web browser to view and control the camera remotely.

## 13.2 Camera image

The M300 camera outputs an IP digital video feed which can be displayed on a video monitor, a Web browser, or a compatible multifunction display (MFD).

Depending on your chosen camera model, the IP digital video feed comprises of:

- A visible image.
- A thermal image.
- Status icons overlaid on the video image.

### Thermal Camera

You should take time to familiarize yourself with the thermal image. This will help you to get the most out of your system:

- Consider every object you view in terms of how it will look “thermally” as opposed to how it looks to your eye. For example look for changes caused by the heating effect of the sun. These are particularly evident right after sunset.
- Experiment with different palettes and scene presets.

- Experiment by looking for hot objects (such as people) compared to the colder surroundings.
- Experiment with the camera for daytime viewing. The camera can provide improved daytime viewing in environments where traditional video camera performance suffers, such as in shadows or backlit scenes.



### Camera status icons

The camera image includes icons to show the current status of the camera.

#### Note:

Icons are colored red if the *[WhiteHot]* or *[BlackHot]* palette is in use, and colored white for all other palettes.

Icon	Description
------	-------------

*[Thermal Camera]* Indicates that the Thermal Camera feed is being controlled by a connected JCU.



*[Visible Camera]* Indicates that the Visible Camera feed is being controlled by a connected JCU.



*[Azimuth (Position)]* Shows the azimuth (or direction) of the camera relative to the vessel. The triangle shows the approximate camera field of view (FOV).

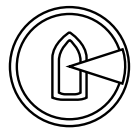

*[Elevation (Tilt)]* Shows the vertical tilt of the camera. The triangle shows the approximate camera position.

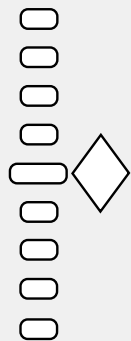

Icon	Description
------	-------------

*[Home]* Indicates the camera is in the home position; the icon flashes when a new home position is set.



*[Lock Zoom]* Locks the zoom factor of the camera to the active payload, whenever possible.



As the two payloads are separate imaging cores, they can each be set to a different zoom factor at the same time. E.g. thermal set to 2x zoom, visible set to 10x zoom. When you "lock the zoom to active", the camera will try to synchronize the two zoom levels.

*[Mirrored View]* Indicates the camera feed is reversed with respect to the vertical axis; it will be the "mirror image" of the original default orientation.

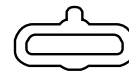



This feature is useful in situations where you have a camera pointing in the opposite direction to the direction of your vessel's travel; i.e. it is a rear-facing camera.

*[Polarity]* Indicates a change in image polarity. For example, if you invert the polarity of a typical monochrome thermal image where white represents hot temperatures, and black represents cold temperatures, the colors will be inverted so that black represents hot temperatures, and white represents cold temperatures.

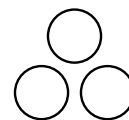

*[Color Palette]* Indicates a change in image color palette.

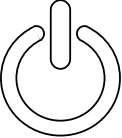

Icon	Description
<p>[NMEA]</p> 	<p>Indicates the NMEA feature is enabled.</p> <p>For more information refer to <a href="#">p.92 — NMEA (Radar Tracking)</a></p>

<p>[Power Down]</p> 	<p>This symbol is displayed to indicate that the camera is shutting down.</p>
---	---

<p>[Scene: Night]</p> 	<p>One of four scene presets (Automatic Gain Control (AGC) settings), optimized for use on the open water at night.</p>
---	---

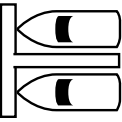
<p>[Scene: Docking]</p> 	<p>One of four scene presets (Automatic Gain Control (AGC) settings), optimized for use when the boat is docking at night.</p>
---	--

<p>[Scene: Day]</p> 	<p>One of four scene presets (Automatic Gain Control (AGC) settings), optimized for use on the open water during the day.</p>
---	---

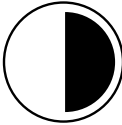
Icon	Description
<p>[Scene: Contrast]</p> 	<p>One of four scene presets (Automatic Gain Control (AGC) settings), optimized for providing visibility to small moving objects.</p>

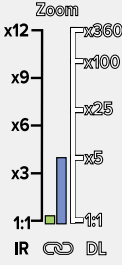
<p>[Zoom Scale]</p> 	<p>Indicates the zoom factor of the active camera.</p>
---	--

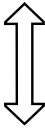
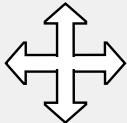
Icon	Description
<p>[Vertical Stabilization]</p> 	<p>Indicates that gyro stabilization is in the vertical setting only. Vertical stabilization is intended to minimize the effects of vessel pitch (while used in a forward or reverse facing position) and vessel roll (while used in a port or starboard facing position).</p>
<p>[Vertical and Horizontal Stabilization]</p> 	<p>Indicates that gyro stabilization is in the vertical and horizontal setting. Vertical stabilization is intended to minimize the effects of vessel pitch (while used in a forward or reverse facing position) and vessel roll (while used in a port or starboard facing position).</p> <p>* Horizontal stabilization is intended to keep the camera pointed in a fixed bearing, even as the vessel turns. For further information, refer to the '<i>Flir Maritime M300 Series Camera Horizontal Stabilization</i>' article found on the FLIR Technical Support Center website: <a href="https://flir.custhelp.com/app/answers/detail/a_id/5798">https://flir.custhelp.com/app/answers/detail/a_id/5798</a></p> <div style="border: 1px solid black; padding: 5px;"> <p><b>Note:</b></p> <p>* Horizontal stabilization is not a form of target tracking. It is best used to reduce the effects of subtle bearing changes when running in a fixed direction. Whenever the vessel makes a notable course change, the camera will need to be manually adjusted to align with the new bearing.</p> </div>

## Image adjustments

### Thermal camera scene presets

Scene presets enable you to quickly select the best image setting for the current environmental conditions.

During normal operation the thermal camera automatically adjusts itself to provide a high-contrast image optimized for most conditions. The Scene presets provide 4 additional settings that may provide better imagery in certain conditions. The 4 modes are:

- **Day** — scene preset mode for daytime conditions.
- **Night** — scene preset mode for night conditions.
- **Docking** — scene preset mode for docking.
- **High Contrast** — scene preset mode for extra-high contrast.

Although the preset names indicate their intended use, varying environmental conditions might make another setting more preferable. For example, the night running scene preset might also be useful while in a harbor. You may find it beneficial to experiment with the different scene presets to discover the best preset to use for different conditions.

### Thermal camera color modes

A range of color modes are available to help you distinguish objects on-screen in different conditions.

Changing the color mode switches the thermal camera image between four available color palettes:

- WhiteHot
- RedHot
- Fusion
- FireIce

The factory default color mode is WhiteHot, which may improve your night vision.

### Thermal camera reverse video

You can reverse the polarity of the video image to change the appearance of objects on-screen.

Changing the polarity setting will toggle between the two available polarities for the color mode that is already selected.

The available polarity options are:

- WhiteHot / BlackHot
- RedHot / RedHot Inverse
- Fusion / Fusion Inverse
- Firelce / Firelce Inverse

You may find it useful to experiment with this option to find the best setting to suit your needs.

### Set camera to Ball-Down mode

Set your camera to Ball-Down mode for Ball-Down (upside down) installations.

#### Note:

The following steps will affect all camera payloads (thermal and visible).

1. Login to your camera's Web browser.
2. Select the *[PTZ]* (Pan Tilt Zoom) tab.
3. Scroll down and select *[Advanced Settings]*.
4. Scroll down to the *[Ball-Down]* setting and select *[On]*. The camera is now set to *[Ball-Down]* mode.
5. To save these settings: select *[System Settings]*.
6. Select *[Firmware & Info]*.
7. Under *[System Default Settings]* select *[Save]*. A notification will pop up to confirm this action.
8. Under *[Reset factory default and reboot]* select *[Reboot]* and select *[Yes]* from the pop up to confirm.
9. After the camera has successfully rebooted it will be set to *[Ball-Down]* mode.

#### Note:

Ball-Down mode can be reverted by repeating the steps above and selecting *[Off]* for the *[Ball-Down]* setting.

## 13.3 Camera control

### Pan, tilt and zoom

The camera controls allow for pan (azimuth) and tilt (elevation) of the camera, as well as zoom (magnification) of the thermal image.

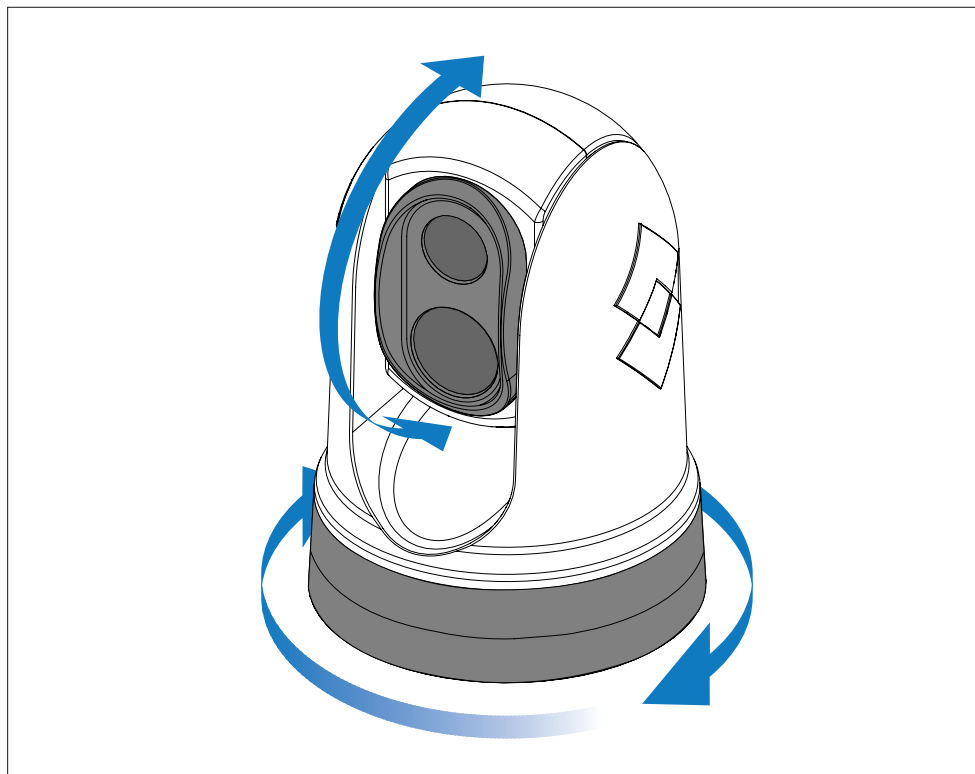

- Pan continuously through 360°.
- Tilt to +110°/-90° relative to the camera base.
- Zoom the thermal camera image.

You can control pan, tilt, and zoom, using:

- A compatible multifunction display: see [p.23 — Compatible multifunction displays](#)
- The joystick on a JCU remote keypad: see [p.83 — JCU-2 controls overview](#)

- The camera's Web browser interface: see [p.68 — Camera operation via Web browser](#)

## Forward position

The forward position is a preset position for the camera.

The forward position usually defines a position facing forward relative to your vessel — for example, straight ahead and level with the horizon.

Icon	Information
	<p>You can set the forward position as required, and return the camera to the forward position, using:</p> <ul style="list-style-type: none"> <li>• A compatible multifunction display: see <a href="#">p.23 — Compatible multifunction displays</a></li> <li>• A JCU remote keypad: see <a href="#">p.83 — JCU-2 controls overview</a></li> <li>• The camera's Web browser interface: see <a href="#">p.68 — Camera operation via Web browser</a></li> </ul>

### Note:

For further information, refer to the 'Flir Maritime M300 Series Home & Forward Position Setting' article found on the FLIR Technical Support Center website: [https://flir.custhelp.com/app/answers/detail/a\\_id/5823/kw/m300](https://flir.custhelp.com/app/answers/detail/a_id/5823/kw/m300)

## Home position

The home position is a preset position for the camera.

The home position usually defines a useful reference point — for example, a view outward from the beam or aft.

Icon	Information
	<p>You can set the home position as required, and return the camera to the home position, using:</p> <ul style="list-style-type: none"> <li>• A compatible multifunction display: see <a href="#">p.23 — Compatible multifunction displays</a></li> <li>• A JCU remote keypad: see <a href="#">p.83 — JCU-2 controls overview</a></li> <li>• The camera's Web browser interface: see <a href="#">p.68 — Camera operation via Web browser</a></li> </ul>

### Note:

For further information, refer to the 'Flir Maritime M300 Series Home & Forward Position Setting' article found on the FLIR Technical Support Center website: [https://flir.custhelp.com/app/answers/detail/a\\_id/5823/kw/m300](https://flir.custhelp.com/app/answers/detail/a_id/5823/kw/m300)

## Surveillance mode

In surveillance mode the camera continuously pans left and right, automatically scanning the scene.

The camera continues scanning until you:

- Disable surveillance mode.
- Manually pan or tilt the camera.
- Command the camera to move to its home position.

Any of these actions stops surveillance mode; surveillance mode does not resume until you re-enable it.

You can control surveillance mode, including the scan speed and scan width, using:

- A compatible multifunction display: see [p.23 — Compatible multifunction displays](#)
- The user programmable buttons on a JCU remote keypad: see [p.84 — Configuring JCU-2 user-programmable buttons \(UPBs\)](#)
- The camera's Web browser interface: see [p.68 — Camera operation via Web browser](#)

# CHAPTER 14: CAMERA OPERATION VIA WEB BROWSER

## CHAPTER CONTENTS

- 14.1 Web browser user interface overview — page 69
- 14.2 Setting up a network connection to the camera — page 69
- 14.3 Logging in to the Web browser user interface — page 70
- 14.4 Video feed — page 71
- 14.5 OSD Menu — page 72
- 14.6 OSD Settings — page 72
- 14.7 Camera settings menus — page 75
- 14.8 Camera settings — page 76
- 14.9 System settings — page 81
- 14.10 Troubleshooting — page 81

## 14.1 Web browser user interface overview

This chapter describes how to use a Web browser to communicate with and configure your M300 Series camera.

M300 Series cameras are network devices that communicate over an Ethernet network using Internet Protocol (IP). Using a Web browser, you can view video, control the camera, and change camera configuration settings.

### Note:

- Changes to configuration settings should only be made by someone who has expertise with M300 Series cameras and a thorough understanding of how the settings affect the image. Haphazard changes can lead to image problems including a complete loss of video.
- You can use various types of IP-networked devices to interact with the camera's Web interface (such as a laptop, PC or tablet). The device must be connected to the same network as the camera (or connected directly), and running the Mozilla Firefox Web browser.

### Note:

- To communicate with and configure your M300 Series camera using a JCU-2 control unit, refer to the following section: [p.82 — Camera operation via JCU](#)
- To communicate with and configure your M300 camera using a compatible multifunction display (MFD), refer to the following section: [p.86 — Camera operation via MFD](#)

## 14.2 Setting up a network connection to the camera

Your camera supports DHCP and UPnP to simplify the process of finding the camera on a network, and connecting to it using a Web browser.

### Note:

The Web browser must be running on a device that is on the same network as the camera.

DHCP (**D**ynamic **H**ost **C**ontrol **P**rotocol) is used to automatically assign IP addresses and other important IP-network parameters to devices on a network. The camera is set to use DHCP by default.

UPnP (**U**niversal **P**lug and **P**lay) is a protocol that helps the camera identify itself to other network devices.

### Note:

You should not attempt to set the camera's IP-network parameters manually unless you have previous experience with configuring IP networks.

To set up a network connection between your IP device (such as a laptop or PC), and the camera:

1.
  - If your system already includes a network switch, connect both the camera and the IP device that will run your Web browser to the switch, then power-on the camera, network switch, and IP device. Refer to the following section for example network connections: [p.47 — Network connections](#)
  - If you don't have any existing networking hardware (such as a network switch), connect the camera and IP device together directly, then power-on the camera and IP device. Refer to the following section for example network connections: [p.47 — Network connections](#)
2. Make sure that your IP device is:
  - a. *configured to obtain an IP address automatically.* For Windows 7, 8, and 10:
    - i. Go to *[Control Panel]*, then *[Network and Sharing Center > Change adapter settings]*.
    - ii. Right-click the network connection corresponding to the wired Ethernet connection on your IP device (often labelled "Local Area Connection") and select *[Properties]*.
    - iii. Select the *[Networking]* tab.
    - iv. Under *[This connection uses the following items]*, select *[Internet Protocol Version 4 (TCP/IPv4)]*.
    - v. Select *[Properties]*.

- vi. Check that the option to *[Obtain an IP address automatically]* is selected.
  - b. *configured to detect UPnP devices*. For Windows 7, 8, and 10:
    - i. Go to *[Control Panel > Network and Sharing Center > Advanced sharing settings]*.
    - ii. Check that the option to *[Turn on network discovery]* is selected.
3. The camera is automatically added to the list of devices located by your IP device, and is named according to the camera part number, and serial number (for example: *E70353 1234*). For Windows 7, 8, and 10, the camera is listed in Windows Explorer under *[Network]*.
4. Under *[Network]*, double-click the camera item to open the camera's Web page. To show more information about the camera, including its IP address, right-click the camera item and select *[Properties]*.

**Note:**

If you are experiencing issues, ensure that you have read and followed the information listed above before referring to the troubleshooting advice found within the following section: [p.97 — System checks and troubleshooting](#)

## 14.3 Logging in to the Web browser user interface

You can log in to the camera's Web interface using:

- User name: *[admin]*
- Password: *[admin]*
- The **admin** login can access the *[Maintenance menu]* and all the other menus. The **admin** login can also create user accounts and change login passwords.

You should change the default login password to prevent unauthorized access.

**Note:**

Only two Web sessions can be active at once.

To log in:

1. Go to the camera's Web page by:
  - entering the camera's IP address directly into the address bar of your Web browser, OR
  - double-clicking the camera in "My Network Places" (Windows XP) or "Network" (later versions of Windows).

For more information, refer to the following section:  
[p.69 — Setting up a network connection to the camera](#)

The login screen is displayed:

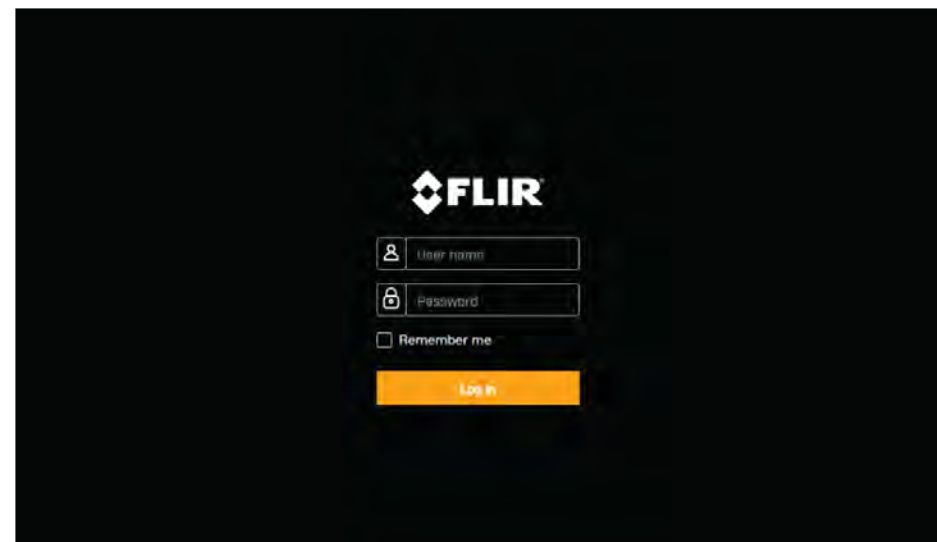

2. Enter *[admin]* for User Name and *[admin]* for Password, then click Log in.

## First time login

After successfully logging into the Web interface for the first time, you will be prompted to enter a new secure password for future use.

### Password requirements

Your password must:

- Contain at least 12 characters.
- Contain at least 1 lowercase character.
- Contain at least 1 uppercase character.
- Contain at least 1 number.

Your password must not:

- Contain special characters (e.g. !"£\$%^&\*).

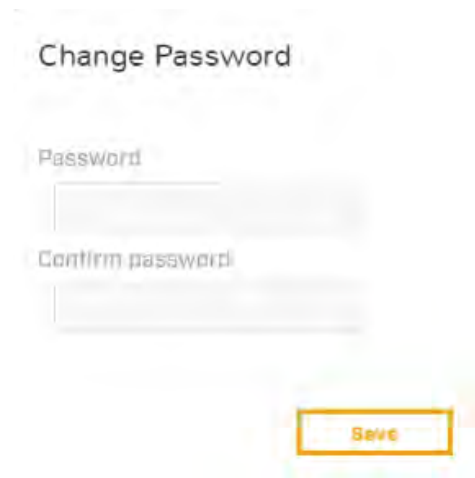

The screenshot shows a web form titled "Change Password". It contains two input fields: "Password" and "Confirm password". Below the fields is a yellow "Save" button. The form is set against a light blue background with a subtle grid pattern.

### Note:

- In low security / leisure camera installations, it is recommended you create an easy to remember password and save a copy of the password in a safe, secure and memorable location.
- If you forget your password contact FLIR support for help with resetting your camera: <https://www.flir.co.uk/support/>

### Important:

Resetting a lost password can only be accomplished with the aid of a FLIR support agent. This action will cause the internal user setting to be reset to factory.

## 14.4 Video feed

After logging in to the camera's Web interface, you can view the live image from the camera's current video stream.

From the top right menu you can:

- Change between the visible and thermal streams using the *[V]* and *[T]* icons.
- Change the camera movement control settings between 2 main modes of operation:
  - *[Joystick]* — select the on-screen “Joystick” icon, and then use the on-screen “directional arrow” controls to pan or tilt the camera in that direction continuously; this will continue until the on-screen cursor is disengaged.
  - *[Cross]* — select the on-screen “cross hairs” icon, and then use the on-screen “directional arrow” controls to center the image at the selected position.
- The icons displayed above the on-screen “directional arrow” controls enable you to change the camera's OSD (On-Screen Display) *[Main Menu]* settings:
  - Select the *[ON / OFF]* button to turn the OSD *[Main Menu]* on or off.
  - Select the *[Directional arrows]* to navigate between each menu selection.
  - Select the *[ENTER]* button to confirm your selection.
  - Select *[CANCEL]* to exit the current menu.

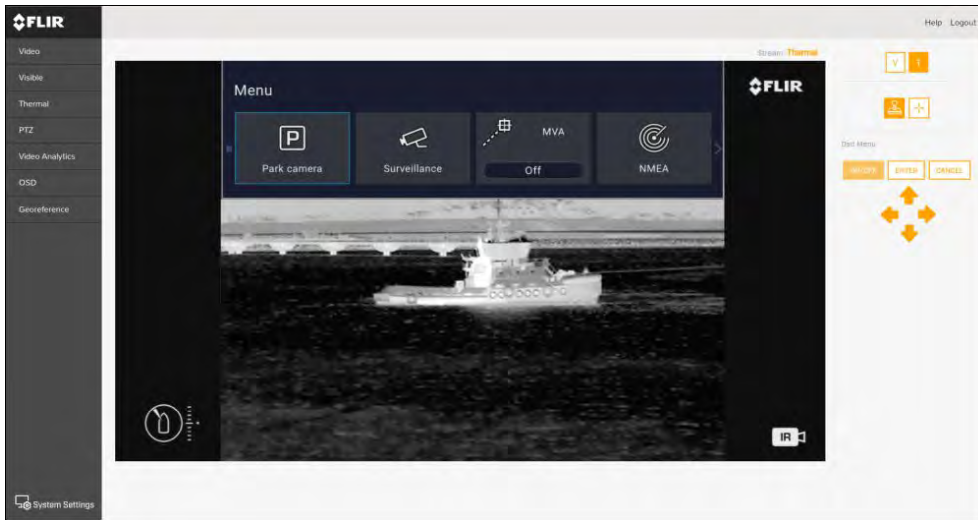

- **[Park Camera]** — The camera will pan and tilt to its predefined Park position. The park position can be defined using the Web browser user interface. For further information, refer to the following section: [p.68 — Camera operation via Web browser](#)
- **[Surveillance]** — In Surveillance mode, the camera pans continuously left and right until it is taken out of surveillance mode, or the video feed is switched.
- **[MVA]** — Access MVA (Marine Video Analytics) settings.
- **[NMEA]** — Enable or disable the processing of external control messages using the NMEA interface.
- **[Image]** — Access advanced image settings.
- **[Settings]** — Access advanced camera settings.
- **[Help]** — Opens the Help menu, which provides access to explanations of on-screen controls and camera features.

## 14.5 OSD Menu

You can access and change the camera's OSD (On-Screen Display) settings via the Web browser user interface or a connected JCU. The menu will be overlaid on the video feed.

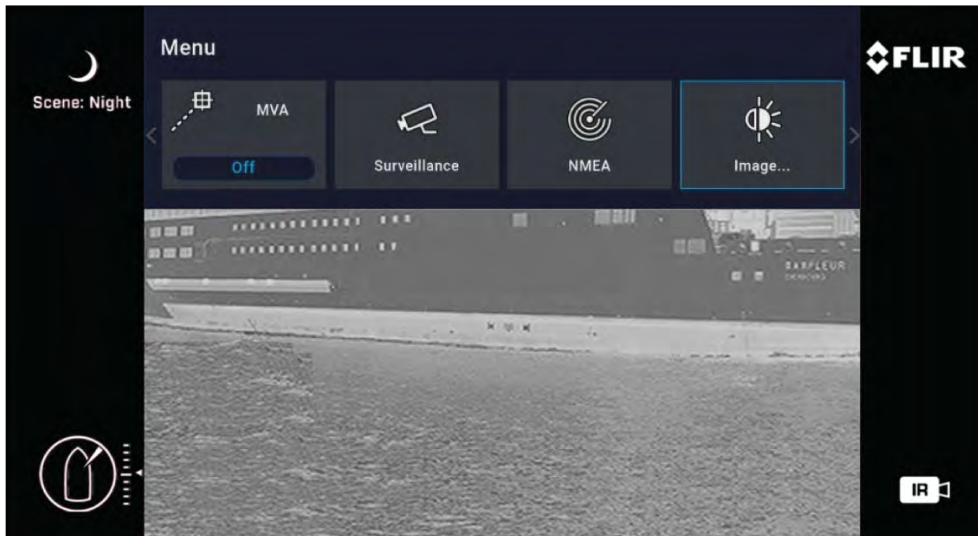

### OSD Menu Icons:

## 14.6 OSD Settings

### Park camera:

Settings	Options
Park Camera	<ul style="list-style-type: none"> <li>• On</li> <li>• Off</li> </ul>

### Surveillance:

Settings	Options
Surveillance	<ul style="list-style-type: none"> <li>• On</li> <li>• Off</li> </ul>

**MVA:**

Settings	Options
MVA	<ul style="list-style-type: none"> <li>• Off</li> <li>• VIS</li> <li>• IR</li> <li>• IR &amp; VIS</li> </ul>

**NMEA:**

Settings	Options
NMEA	<ul style="list-style-type: none"> <li>• On</li> <li>• Off</li> </ul>

**Image:**

Settings	Options
Active camera	<ul style="list-style-type: none"> <li>• VIS</li> <li>• IR</li> </ul>
Stabilization	<ul style="list-style-type: none"> <li>• Off</li> <li>• Vertical</li> <li>• Horizontal &amp; Vertical</li> </ul>
CTV	<ul style="list-style-type: none"> <li>• On</li> <li>• Off</li> </ul>

**Note:**  
Applies to dual payload cameras only.

Settings	Options
MSX	<ul style="list-style-type: none"> <li>• On</li> <li>• Off</li> </ul>
	<div data-bbox="1648 272 2065 405" style="border: 1px solid black; padding: 5px;"> <p><b>Note:</b> Applies to dual payload cameras only.</p> </div>
Polarity	<ul style="list-style-type: none"> <li>• RedHot</li> <li>• BlackHot</li> </ul>
Color	<ul style="list-style-type: none"> <li>• Greyscale</li> <li>• Redscale</li> <li>• Fusion</li> <li>• Firelce</li> </ul>
Scene	<ul style="list-style-type: none"> <li>• Night</li> <li>• Day</li> <li>• High contrast</li> <li>• Dock</li> </ul>
VIS low light mode	<ul style="list-style-type: none"> <li>• On</li> <li>• Off</li> <li>• Auto</li> </ul>
IR / VIS zoom link	<ul style="list-style-type: none"> <li>• On</li> <li>• Off</li> </ul>
Mirrored view	<ul style="list-style-type: none"> <li>• On</li> <li>• Off</li> </ul>

## Settings:

Settings	Options
Save current settings as defaults	<ul style="list-style-type: none"><li>• Activate</li></ul>
Restore settings from defaults	<ul style="list-style-type: none"><li>• Activate</li></ul>
Restore factory settings	<ul style="list-style-type: none"><li>• Activate</li></ul>

## Settings (Advanced image):

Settings	Options
IR eZoom	<ul style="list-style-type: none"><li>• On</li><li>• Off</li></ul>
VIS eZoom	<ul style="list-style-type: none"><li>• On</li><li>• Off</li></ul>
VIS wide dynamic range	<ul style="list-style-type: none"><li>• On</li><li>• Off</li></ul>
VIS electronic stabilization	<ul style="list-style-type: none"><li>• On</li><li>• Off</li></ul>
VIS camera defog	<ul style="list-style-type: none"><li>• On</li><li>• Off</li></ul>
VIS MVA Threshold	<ul style="list-style-type: none"><li>• 1–16</li></ul>
IR MVA Threshold	<ul style="list-style-type: none"><li>• 1–16</li></ul>
VIS MVA Environment	<ul style="list-style-type: none"><li>• Coastal</li><li>• Open Sea</li></ul>
IR MVA Environment	<ul style="list-style-type: none"><li>• Coastal</li><li>• Open Sea</li></ul>
MSX Blend Percentage	<ul style="list-style-type: none"><li>• 0–100</li></ul>
CTV Blend Percentage	<ul style="list-style-type: none"><li>• 0–100</li></ul>

## Settings (User interface):

Settings	Options
Interface language	<ul style="list-style-type: none"><li>• English</li><li>• Español</li><li>• Türkçe</li></ul>
Pilot mode	<ul style="list-style-type: none"><li>• On</li><li>• Off</li></ul>
Display icons	<ul style="list-style-type: none"><li>• Minimal</li><li>• Custom</li><li>• Full</li></ul>
Help text	<ul style="list-style-type: none"><li>• On</li><li>• Off</li></ul>
Icon & text color	<ul style="list-style-type: none"><li>• White</li><li>• Red</li></ul>
User 1, User 2, User 3	<ul style="list-style-type: none"><li>• Vert stab</li><li>• V &amp; H stab</li><li>• Surveillance</li><li>• Mirrored view</li><li>• Icon levels</li><li>• Polarity</li><li>• MSX</li><li>• CTV</li></ul>
Set Az & El zero reference	<ul style="list-style-type: none"><li>• Set Origin</li><li>• No</li></ul>

### Settings (Surveillance):

Settings	Options
Scan width	<ul style="list-style-type: none"><li>• Small</li><li>• Medium</li><li>• Large</li></ul>
Scan speed	<ul style="list-style-type: none"><li>• Slow</li><li>• Medium</li><li>• Fast</li></ul>

### Settings (NMEA):

Settings	Options
Radar cursor (RSD)	<ul style="list-style-type: none"><li>• On</li><li>• Off</li></ul>
Next waypoint (BWC)	<ul style="list-style-type: none"><li>• On</li><li>• Off</li></ul>
Radar target (TTM)	<ul style="list-style-type: none"><li>• On</li><li>• Off</li></ul>

### Help:

Settings	Options
About	<ul style="list-style-type: none"><li>• Camera</li><li>• Versions</li><li>• Contact</li></ul>
User guide	<ul style="list-style-type: none"><li>• Quick start guide</li></ul>

## 14.7 Camera settings menus

You can access different camera settings menus on the left side of the video stream. The settings contained in these menu pages can be used to configure your camera.

- *[Video]* — Edit general video settings.
- *[Visible]* — Edit the visible camera settings.
- *[Thermal]* — Edit the thermal camera settings.
- *[PTZ (Pan Tilt Zoom)]* — Edit the Pan Tilt and Zoom settings and control the camera.
- *[Video Analytics]* — Edit MVA (Marine Video Analytics) and object detection settings.
- *[OSD (On Screen Display)]* — Edit the on-screen status symbols and icons displayed on the video feed.
- *[Georeference]* — Edit the camera's altitude above the waterline.

## 14.8 Camera settings

### Video:

Settings	Options
Video profile	<ul style="list-style-type: none"> <li>• T1 (Thermal profile 1)</li> <li>• T2 (Thermal profile 2)</li> <li>• V1 (Visible 1)</li> <li>• V1 (Visible 2)</li> </ul>
<p><b>Note:</b> Visible and Thermal video profiles are dependent on camera model</p>	
Codec	<ul style="list-style-type: none"> <li>• H.264</li> <li>• MJPEG</li> <li>• Baseline Profile</li> <li>• Main Profile</li> <li>• High Profile</li> </ul>
Resolution	<ul style="list-style-type: none"> <li>• 640x360</li> <li>• 854x480</li> <li>• 960x540</li> <li>• 1280x720</li> <li>• 1920x1080</li> </ul>
Frame Rate	<ul style="list-style-type: none"> <li>• 1–30</li> </ul>
Rate control	<ul style="list-style-type: none"> <li>• CBR</li> <li>• VBR</li> </ul>
Bit Rate [KBPS]	<ul style="list-style-type: none"> <li>• 32–102400</li> </ul>
I-frame Interval	<ul style="list-style-type: none"> <li>• 1–300</li> </ul>

Settings	Options
Enable Multicast	<ul style="list-style-type: none"> <li>• No</li> <li>• Yes</li> </ul>
<p><b>Note:</b> When enabled, the Multicast setting reduces the total amount of network traffic on your system by simultaneously distributing the camera's video feed data to multiple configured devices. For more information, refer to: <a href="#">p.54 — Multicasting</a></p>	
Destination Address	<ul style="list-style-type: none"> <li>• Enter Value</li> </ul>
Destination Port	<ul style="list-style-type: none"> <li>• Enter Value</li> </ul>
TTL	<ul style="list-style-type: none"> <li>• Enter Value</li> </ul>

### Visible:

Settings	Options
E-Flip	<ul style="list-style-type: none"> <li>• On</li> <li>• Off</li> </ul>
Reverse	<ul style="list-style-type: none"> <li>• On</li> <li>• Off</li> </ul>
Freeze	<ul style="list-style-type: none"> <li>• On</li> <li>• Off</li> </ul>
Picture Effect	<ul style="list-style-type: none"> <li>• Off</li> <li>• Negative Art</li> <li>• Black &amp; White</li> </ul>
Contrast Adjustment	<ul style="list-style-type: none"> <li>• 0%–100%</li> </ul>
Color Gain	<ul style="list-style-type: none"> <li>• 0%–100%</li> </ul>

Settings	Options
Auto Exposure Mode	<ul style="list-style-type: none"> <li>• Full Auto</li> <li>• Manual</li> <li>• Shutter Priority</li> <li>• Iris Priority</li> </ul>
Exposure Comp	<ul style="list-style-type: none"> <li>• On</li> <li>• Off</li> </ul>
Spot Auto Exposure	<ul style="list-style-type: none"> <li>• On</li> <li>• Off</li> </ul>
Slow Shutter	<ul style="list-style-type: none"> <li>• On</li> <li>• Off</li> </ul>
Backlight Compensation	<ul style="list-style-type: none"> <li>• On</li> <li>• Off</li> </ul>
Exposure	0–14
Shutter	0–21
Gain	0–17
Iris	1–100
ICR Mode (Low Light)	<ul style="list-style-type: none"> <li>• On</li> <li>• Off</li> <li>• Auto</li> </ul>
Stabilization	<ul style="list-style-type: none"> <li>• On</li> <li>• Off</li> </ul>
Wide Dynamic Range Mode	<ul style="list-style-type: none"> <li>• Off</li> <li>• On</li> <li>• Visibility Enhancer On</li> </ul>
Display Brightness	• 0–6

Settings	Options
Brightness Compensation	<ul style="list-style-type: none"> <li>• Very Dark</li> <li>• Dark</li> <li>• Standard</li> <li>• Bright</li> </ul>
Compensation Level	<ul style="list-style-type: none"> <li>• Low</li> <li>• Mid</li> <li>• High</li> </ul>
White Balance Mode	<ul style="list-style-type: none"> <li>• Auto</li> <li>• Outdoor</li> <li>• Indoor</li> <li>• One Push</li> <li>• ATW</li> <li>• Manual</li> </ul>
Defog	<ul style="list-style-type: none"> <li>• Off</li> <li>• Low</li> <li>• Mid</li> <li>• High</li> </ul>
Lens	<ul style="list-style-type: none"> <li>• Manual</li> <li>• Auto</li> </ul>
Focus	• 0%–100%
Autofocus Mode	<ul style="list-style-type: none"> <li>• Normal</li> <li>• Interval</li> <li>• Zoom Trigger</li> </ul>
Autofocus Sensitivity	<ul style="list-style-type: none"> <li>• Normal</li> <li>• Low</li> </ul>
Focus Rate	• 0–100
Zoom Rate	• Select

Settings	Options
Initialize Lens	• Select
Focus to Infinity	• Select
Autofocus Push	• Select
Aperture — High Sensitivity	• On • Off
Aperture	• 0–15
Noise Reduction	• Off • 1 • 2 • 3 • 4 • 5 • 2D NR/3D NR
2D NR Level	• 0–5
3D NR Level	• 0–5
Gamma Mode	• Standard • Straight
Offset	• 0–100
Ezoom	• On • Off

### Thermal:

Settings	Options
AGC RDI	• Custom • Full Screen • Horizon • Sky • Ground • Centre 75 • Centre 50 • Centre 25
Ace	• 0.5–4
Max Gain	• 0.25–8
DDE	• 0–8
Damping Factor	• 0–100
Tail Rejection	• 0–49
Plateau Value	• 1–100
Linear Percent	• 1–100
Detail Headroom	• 0–127
Smoothing Factor	• 0–8191
Information-Based Mode	• On • Off

Settings	Options
Colorization	<ul style="list-style-type: none"> <li>• WhiteHot</li> <li>• BlackHot</li> <li>• RedHot</li> <li>• RedHot Inverse</li> <li>• Fusion</li> <li>• Fusion Inverse</li> <li>• Firelce</li> <li>• Firelce Inverse</li> </ul>
Blend Mode	<ul style="list-style-type: none"> <li>• Off</li> <li>• CTV</li> <li>• MSX</li> <li>• 0–100</li> </ul>
Blending Registration Offset:	<ul style="list-style-type: none"> <li>• –32–32</li> </ul>
	<ul style="list-style-type: none"> <li>• X</li> <li>• Y</li> <li>• Width</li> <li>• Height</li> </ul>
Mirroring/Inversion	<ul style="list-style-type: none"> <li>• Ball-down Off / Rearview Off</li> <li>• Ball-down On / Rearview Off</li> <li>• Ball-down Off / Rearview On</li> <li>• Ball-down On / Rearview On</li> </ul>
Scene Presents	<ul style="list-style-type: none"> <li>• Night</li> <li>• Day</li> <li>• High Contrast</li> <li>• Docking</li> </ul>

Settings	Options
FFC	<ul style="list-style-type: none"> <li>• Manual</li> <li>• Auto</li> <li>• Ext.</li> </ul>
FFC Period (Seconds)	<ul style="list-style-type: none"> <li>• Enter Value</li> <li>• Apply</li> </ul>
Temp Change (0.1 °C)	<ul style="list-style-type: none"> <li>• Enter Value</li> <li>• Apply</li> </ul>
FFC Integration Period (Frames)	<ul style="list-style-type: none"> <li>• 2</li> <li>• 4</li> <li>• 8</li> <li>• 16</li> <li>• Perform FFC</li> </ul>
Ezoom	<ul style="list-style-type: none"> <li>• On</li> <li>• Off</li> </ul>
High-To-Low Intensity Threshold	• 0–49
High-To-Low Population Threshold	• 0–49
Low-To-High Population Threshold	• 0–49

#### PTZ:

Settings	Options
Pan / Tilt	<ul style="list-style-type: none"> <li>• Tilt left</li> <li>• Tilt right</li> <li>• Pan left</li> <li>• Pan right</li> </ul>
Speed	• 1–10
Pilot Mode	<ul style="list-style-type: none"> <li>• Yes</li> <li>• No</li> </ul>

Settings	Options
Zoom	<ul style="list-style-type: none"> <li>• Zoom out</li> <li>• Zoom in</li> </ul>
Sync Visible Zoom	<ul style="list-style-type: none"> <li>• Enabled</li> <li>• Disabled</li> </ul>
Home Position	<ul style="list-style-type: none"> <li>• Go to</li> <li>• Set</li> </ul>
Park Position	<ul style="list-style-type: none"> <li>• Go to</li> <li>• Set</li> </ul>
Present Position	<ul style="list-style-type: none"> <li>• Select Position.</li> </ul>
Set Preset (Index)	<ul style="list-style-type: none"> <li>• 1–128</li> </ul>
Preset Name	<ul style="list-style-type: none"> <li>• Enter Description</li> </ul>
Stabilization	<ul style="list-style-type: none"> <li>• On</li> <li>• Off</li> </ul>
Horizontal Stabilization	<ul style="list-style-type: none"> <li>• On</li> <li>• Off</li> </ul>
Ball-Down	<ul style="list-style-type: none"> <li>• On</li> <li>• Off</li> </ul>
Forward Position	<ul style="list-style-type: none"> <li>• Set</li> </ul>
Relative Auto Scan — Width	<ul style="list-style-type: none"> <li>• Narrow</li> <li>• Medium</li> <li>• Wide</li> </ul>
Relative Auto Scan — Speed	<ul style="list-style-type: none"> <li>• Low</li> <li>• Medium</li> <li>• High</li> </ul>
Relative Auto Scan	<ul style="list-style-type: none"> <li>• Save</li> <li>• Start</li> <li>• Stop</li> </ul>

### Video Analytics:

Settings	Options
Enable	<ul style="list-style-type: none"> <li>• None</li> <li>• Visible</li> <li>• Thermal</li> <li>• Both</li> </ul>
Profile	<ul style="list-style-type: none"> <li>• Thermal</li> <li>• Visible</li> </ul>
Threshold	<ul style="list-style-type: none"> <li>• 1–16</li> </ul>
Environment	<ul style="list-style-type: none"> <li>• Open Sea</li> <li>• Coastal</li> </ul>

### OSD:

Settings	Options
Display Icons	<ul style="list-style-type: none"> <li>• Full</li> <li>• Minimal</li> <li>• Custom</li> </ul>
Help Text	<ul style="list-style-type: none"> <li>• On</li> <li>• Off</li> </ul>
OSD Language	<ul style="list-style-type: none"> <li>• English</li> <li>• Español</li> <li>• Türkçe</li> </ul>

### Georeference:

Settings	Options
Altitude (Meters)	<ul style="list-style-type: none"> <li>• Set Altitude</li> </ul>

## 14.9 System settings

You can access the following advanced camera settings and diagnostic information by selecting *[System Settings]* at the bottom of the screen.

- Network
- Date & Time
- Users
- JCU
- OSD
- Temperature
- Cyber
- ONVIF
- Video Outputs
- Radar
- Firmware & info

## 14.10 Troubleshooting

### Setting a static IP address

In some circumstances, you may need to set a static IP address for the camera's IP-network, rather than relying on the automatic IP addresses provided by the DHCP server (the camera's default setting).

#### Note:

Unless you are specifically instructed in FLIR documentation, or have previous experience of configuring IP networks, you should NOT attempt to set the camera's IP-network parameters manually. If you mis-configure the IP-network parameters, your camera may stop working correctly or become inaccessible on the network.

This procedure assumes that you have already established a network connection, and can access the camera's Web interface. To configure the camera's IP network parameters manually:

[Camera operation via Web browser](#)

1. Log into the camera's Web interface.  
For more information on logging in, refer to:  
[p.70 — Logging in to the Web browser user interface](#)
2. From the Web Interface *[Homescreen]*, select *[System Settings]* from the bottom left of the screen.
3. Select *[Network]*.
4. Select the *[DNS Mode]* drop down menu and select *[Static]*.
5. Select the *[Host Name]* drop down menu and select *[Static]*.
6. Adjust the values for *[IP Address]* and *[Netmask]* as required.

#### Important:

Keep a record of the changes made. You will need this address to access the camera's Web interface in future.

7. At the bottom of the page, select *[Save]*.

# CHAPTER 15: CAMERA OPERATION VIA JCU

## CHAPTER CONTENTS

- 15.1 JCU operation — page 83
- 15.2 JCU-2 controls overview — page 83

## 15.1 JCU operation

You can access and change the camera OSD (On-Screen Display) settings via a connected Joystick Control Unit (JCU).

Via a connected JCU, you can:

- Press the *[Menu]* button to turn the OSD *[Main Menu]* on or off.
- Use the *[Joystick]* to navigate camera setting menus.
- Press the *[Right Joystick]* button to confirm a menu setting selection.
- Press the *[Left Joystick]* button to exit the current menu.

For further information on the camera OSD (On-Screen Display) settings, refer to the following section: [p.72 — OSD Menu](#)

## 15.2 JCU-2 controls overview

The camera can be controlled with a JCU-2.

### Note:

- The JCU-2 joystick control unit is available separately as an optional accessory (part number: 500-0398-10).
- For more information on other compatible JCU units refer to [p.22 — Compatible joystick controllers \(JCU\)](#)

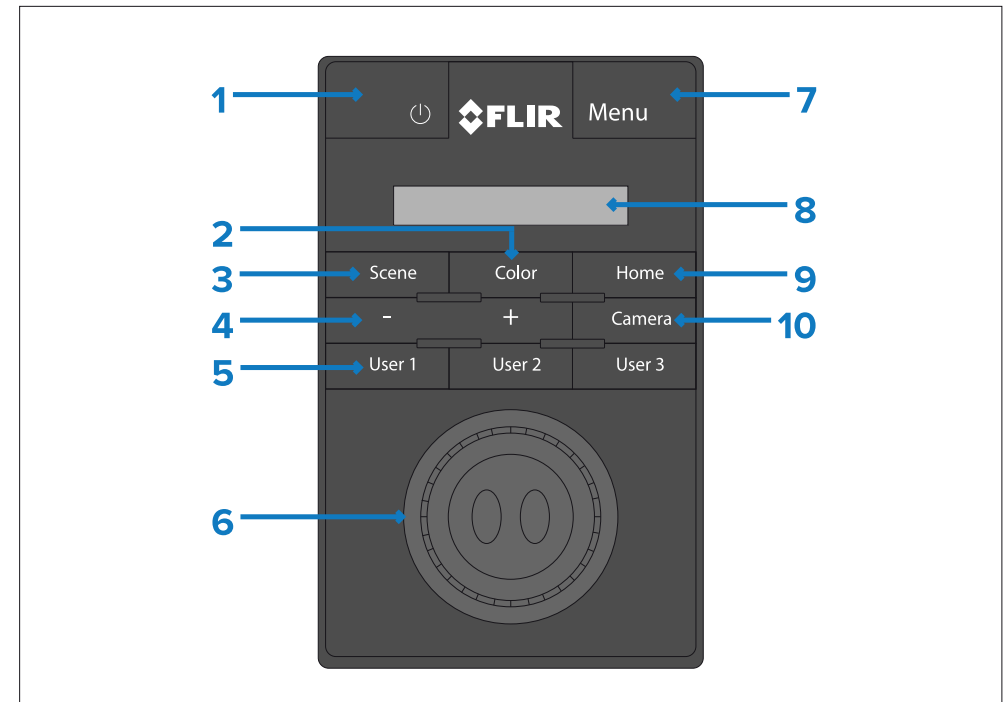

Item	Description
1	<b>[POWER]</b> <ul style="list-style-type: none"><li>• Press to cycle JCU-2 display brightness <i>[Dim &gt; Normal &gt; Bright]</i>.</li><li>• Press and hold to wake camera or enter power menu.</li></ul>
2	<b>[COLOR]</b> <ul style="list-style-type: none"><li>• Press to change palette.</li><li>• Press and hold to change polarity.</li></ul>
3	<b>[SCENE]</b> <ul style="list-style-type: none"><li>• Press to change scene settings.</li></ul>
4	<b>[ZOOM]</b> <ul style="list-style-type: none"><li>• + — Press to adjust thermal eZoom.</li></ul>

Item	Description
5	<p><i>[USER 1, USER 2, USER 3]</i></p> <ul style="list-style-type: none"> <li>User programmable buttons (default action is “toggle rear-view mirror mode”) configured via the camera’s Web page: see <a href="#">p.84 — Configuring JCU-2 user-programmable buttons (UPBs)</a></li> </ul>
6	<p><i>[JOYSTICK]</i></p> <p><b>To Manage Camera</b></p> <ul style="list-style-type: none"> <li>Twist to zoom camera.</li> <li>Push fore / aft to tilt camera.</li> <li>Push left or right to rotate camera.</li> </ul> <p><b>To Navigate On-Screen Menus</b></p> <ul style="list-style-type: none"> <li>Push left / right / up /down to highlight menu item.</li> <li>Push right joystick button to select menu item.</li> <li>Push left / right to change numeric value.</li> <li>Push right joystick button to toggle switch.</li> <li>Push left joystick button to exit current menu item.</li> </ul> <p><b>To Navigate JCU LCD Menu</b></p> <ul style="list-style-type: none"> <li>Push fore / aft to scroll up / down.</li> <li>Push left joystick button to select menu item.</li> </ul>
7	<p><i>[MENU]</i></p> <ul style="list-style-type: none"> <li>Press to enable on-screen menu.</li> <li>Press to exit menu.</li> </ul>
8	<p><i>[LCD DISPLAY]</i></p> <ul style="list-style-type: none"> <li>Displays JCU information and power menu options.</li> <li>Use joystick to interact.</li> </ul>

Item	Description
9	<p><i>[HOME]</i></p> <ul style="list-style-type: none"> <li>Press to return to home position.</li> <li>Press and hold until home icon flashes to store new home position.</li> </ul>
10	<p><i>[CAMERA]</i></p> <ul style="list-style-type: none"> <li>Press to select active camera.</li> </ul>

## Configuring JCU-2 user-programmable buttons (UPBs)

### Note:

The JCU-2 joystick control unit is available separately as an optional accessory.

The JCU-2 keypad’s user-programmable buttons (UPBs) can be configured using the camera’s Web interface. For more information on accessing the Web interface refer to the following section: [p.68 — Camera operation via Web browser](#)

You can assign a different action to each UPB (for example, “Vertical stabilization”, or “Surveillance mode”) on a per-camera basis.

### Note:

UPB mappings apply to individual cameras rather than to specific JCU-2 keypads. This means that, if you are using a single JCU-2 keypad to control two M300 Series cameras, UPB number 1 could be configured to initiate a different action on each camera.

To configure JCU-2 user programmable buttons (UPBs) using the camera’s Web interface:

- From the camera’s Web interface, select *[System Settings]* at the bottom left of the menu.  
The Settings menus are displayed.
- From the menus at the top select *[JCU]*.  
The *[JCU]* setting page is displayed.

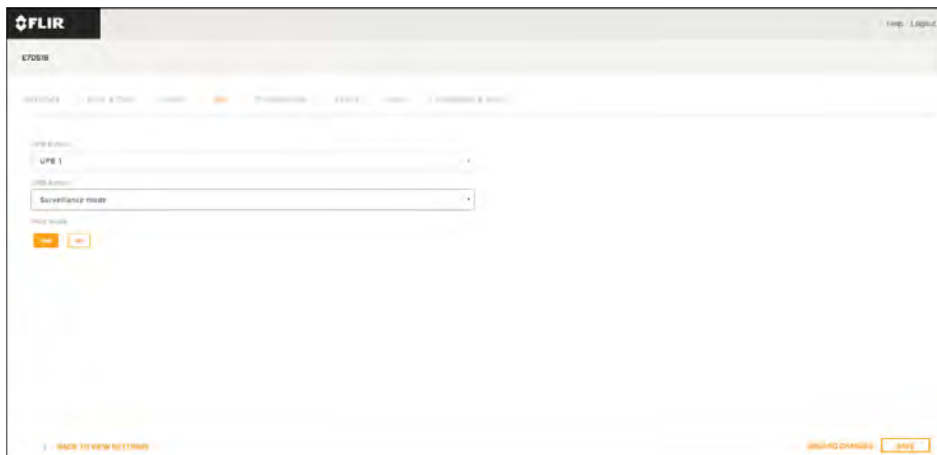

3. From the *[UPB Button]* list, select the button you wish to configure.
4. From the *[UPB Action]* list, choose the camera action you wish to associate with that UPB button.
5. Repeat steps 3 and 4 for each UPB you wish to configure.
6. Select *[Save]* to save the UPB Configuration.

# CHAPTER 16: CAMERA OPERATION VIA MFD

## CHAPTER CONTENTS

- 16.1 Overview — page 87

## 16.1 Overview

You can view the camera's video feed and also control the camera by using a MFD equipped with a MJPEG codec supported Web browser.

Some MFDs may also support further control options via a dedicated video / camera application, which must be compatible with ONVF (Profile S). The range of camera control options available will be dependent on the support that your MFD manufacturer has developed for their video / camera application.

### Note:

It is recommended that you use a dedicated video / camera application in order to:

- View an improved camera video feed quality (via the H.264 video codec).
  - Avoid Web browser session expiration.
- 
- For information on how to operate the camera via a Web browser, refer to the following section: [p.68 — Camera operation via Web browser](#)
  - For information on whether you can operate the camera via your MFDs dedicated video / camera application and how, refer to the documentation which accompanies your display and your MFD manufacturer.

# CHAPTER 17: MARINE VIDEO ANALYTICS (MVA)

## CHAPTER CONTENTS

- 17.1 Overview — page 89
- 17.2 Enabling MVA via the camera's Web interface — page 89
- 17.3 Enabling MVA via the camera's on-screen display and JCU — page 90

## 17.1 Overview

The Marine Video Analytics (MVA) feature alerts you when “non-water” objects are identified in the scene. Boats, obstacles, and navigation markers can all be automatically identified in a scene when this feature is enabled.



### Important:

MVA performance is dependent on conditions, and is not a replacement for maintaining a visual watch.

### Important:

Weather conditions can cause the target’s temperature, luminance, contrast or chrominance to be below a detectable range in relation to the background image. Therefore, the effectiveness of the MVA feature for distinguishing targets and non-targets is dependent on optimal scene conditions. It is recommended that:

- The visible image is adjusted to contain good color, brightness and contrast;
- The *[Threshold]* setting in the *[Video Analytics]* menu is adjusted to ensure that irrelevant regions such as sun glare are excluded from the object detection.

MVA can be activated using:

- The camera’s Web interface.
- The camera’s on-screen display, via a connected JCU.

## 17.2 Enabling MVA via the camera’s Web interface

You can enable MVA using the camera’s Web interface.

1. Log into the camera’s Web interface.

### Important:

For more information on how to log in refer to [p.70 — Logging in to the Web browser user interface](#)

2. From the menu on the left, select *[Video Analytics]*.
3. From the drop-down menu below *[Enable]*, select the payload you want *[Object Detection]* enabled on: *[Visible]*, *[Thermal]* or *[Both]*.

### Important:

Payload choice is dependent on camera model.

From the *[Video Analytics]* menu you can adjust the Object Detection feature settings:

- **[Payload]** — select which payload to adjust settings for:
  - **[Visible]**
  - **[Thermal]**
- **[Threshold]** — adjusting the threshold value will increase or decrease the camera payload's sensitivity for detecting objects:
  - **[1]** is the lowest threshold and will show all small and distant detected objects.
  - **[16]** is the maximum threshold and will only show prominent objects detected by the camera.
- **[Environment]** — select the environment you are using object detection in:
  - **[Coastal]** has more filtering to reduce false detections of land.
  - **[Open sea]** has less filtering so may identify land as an object.

2. Scroll through the menu and select **[MVA]**.
3. From the drop-down menu, select the payload you want: **[Object Detection]** enabled on: **[Visible (VIS)]**, **[Thermal (IR)]** or **[Both]**.

### Important:

Payload choice is dependent on camera model.

Object Detection settings can be found in the settings menu: **[Menu > Settings > Advanced image]**

- **[VIS / IR Threshold]** — adjusting the threshold value will lower or increase the camera payload's sensitivity for detecting objects:
  - **[1]** is the lowest threshold and will show all small and distant detected objects.
  - **[16]** is the maximum threshold and will only show prominent objects detected by the camera.
- **[VIS / IR Environment]** — for each of the camera's payloads, select the type of external environment you are using object detection in:
  - **[Coastal]** has more filtering to reduce false detections of land.
  - **[Open sea]** has less filtering, and may identify land as an object.

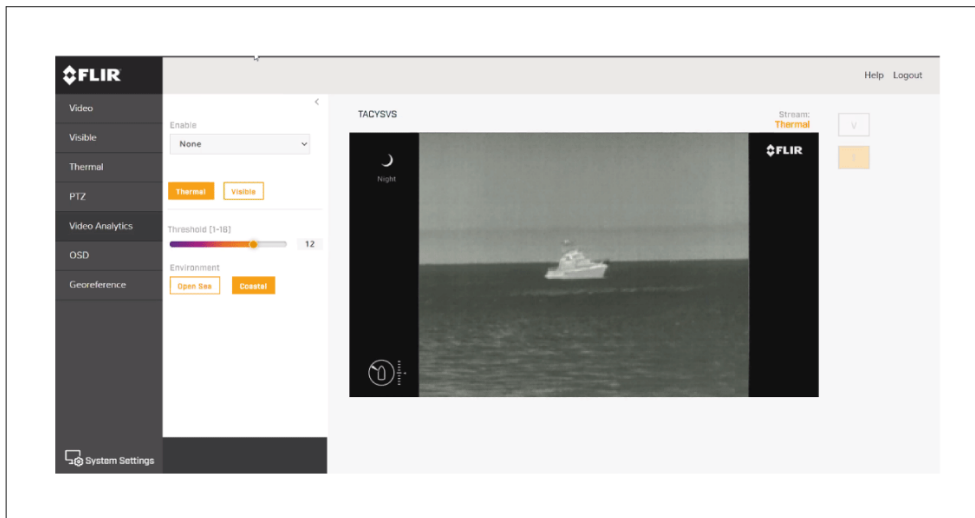

## 17.3 Enabling MVA via the camera's on-screen display and JCU

You can enable MVA using the camera's on-screen display and a connected JCU.

1. Press the **[Menu]** button on the connected JCU to open the on-screen display menu.

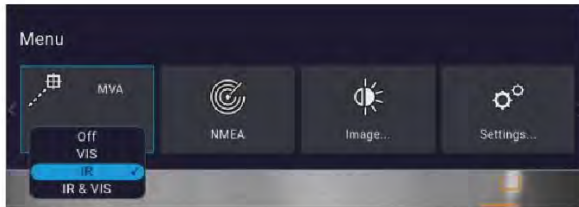

# CHAPTER 18: NMEA (RADAR TRACKING)

## CHAPTER CONTENTS

- 18.1 NMEA 0183 overview — page 93
- 18.2 Enabling NMEA 0183 via the camera's web interface — page 93
- 18.3 Enabling NMEA 0183 via the camera's on-screen display — page 94

## 18.1 NMEA 0183 overview

The NMEA interface allows the camera to communicate with radar, GPS, or other third-party devices using the National Marine Electronics Association (NMEA) 0183 protocol. NMEA 0183 (or NMEA for short) is a combined electrical and data specification for communication between marine electronic devices.

For information on how to connect NMEA 0183 devices to the camera, refer to: [p.45 — NMEA 0183 connection](#)

For additional information regarding the NMEA 0183 protocol refer to: <https://www.nmea.org/content>

The NMEA 0183 protocol allows the camera to automatically point itself towards vessels and other objects in its field of view, and to track their movement. The camera can receive 3 types of NMEA messages:

- **Radar Cursor Tracking**, which is implemented using the NMEA Radar System Data (**RSD**) sentence.
- **Slew to Waypoint**, which uses the NMEA Bearing and Distance to Waypoint, Great Circle (**BWC**) sentence.
- **Radar Tracking**, which uses the NMEA Tracked Target Message (**TTM**) sentence.

### Note:

Even though you can only choose three types of messages to enable through the NMEA interface, the cameras use additional messages to perform the calculations needed to respond to these three. If your system is not responding as expected, verify that the NMEA device sending messages is sending the following additional message types:

- HDT (Heading — True)
- GGA (Global Positioning System Fix Data)
- VHW (Water Speed and Heading)
- OSD (Own Ship Data)
- TLL (Target Latitude and Longitude)

### Note:

Any combination or all 3 of these NMEA messages can be enabled; when more than one type is enabled, the system processes **RSD** first, then **BWC**, and finally **TTM**. For example, if the unit is listening to **BWC** or **TTM** messages and looking at a particular target and it receives an **RSD** message, it waits until the end of the dwell time and then moves on to the **RSD** message, ignoring all other input.

### Important:

In order for the NMEA features to work correctly, the camera's altitude above the waterline must be specified using the camera's Web interface. Enter the altitude by accessing the Web interface and selecting the *[Georeference]* tab.

## 18.2 Enabling NMEA 0183 via the camera's web interface

You can enable NMEA 0183 using the camera's Web interface.

1. Log into the camera's Web interface.

### Important:

For more information on how to log in, refer to: [p.70 — Logging in to the Web browser user interface](#)

2. At the bottom left of the screen, select *[System Settings]*.
3. From the top menu, select *[Radar]*.
4. Use the drop-down menu to select your connected radar.
5. Set the *[Dwell Time]* using the slider.

*[Dwell Time]* is the length of time the camera will focus on each radar target before switching focus to the next target.

6. At the bottom right of the screen, select *[Save]* to save these settings.

## 18.3 Enabling NMEA 0183 via the camera's on-screen display

You can enable NMEA 0183 using the camera's on-screen display and a connected JCU.

1. Press the *[Menu]* button on the connected JCU to open the on-screen display menu.
2. Scroll through the menu and select *[NMEA]* to toggle NMEA On / Off.  
**When NMEA is enabled it will display a radar symbol on the camera feed.**

NMEA settings can be found in the settings menu *[Menu > Settings > NMEA]*

- *[Radar Cursor (RSD)]* — you can control the camera by using the cursor on the radar display to highlight a target. The camera will pan to whichever target is selected by the cursor. If you move the cursor on the radar display to a different target, the camera will move accordingly. This function is also known as “radar cursor tracking”.
- *[Next Waypoint (BWC)]* — the camera will pan in the direction of a specific waypoint, when your vessel comes within 3 NM (5 Km) of the waypoint location. This function is also known as “slew to waypoint”.
- *[Radar Target (TTM)]* — the camera will automatically and continuously pan to whichever target is selected on the Radar display. This function is also known as “slew to cue”. It is possible to track multiple radar targets. Once targets are selected, the camera will automatically pan to “track” each target sequentially. In this scenario, the camera will remain “locked-on” to each target for approximately 10 seconds, before moving to the next target. Due to the way that Radar operates, it is possible to lose a target momentarily. To ensure that the tracking process continues after the momentary loss of a target, the TTM function maintains the last known position of the target in its queue for 60 seconds after receiving the last valid message. After 60 seconds, that target is removed from the queue.



# CHAPTER 19: MAINTENANCE

## CHAPTER CONTENTS

- 19.1 Service and maintenance — page 96
- 19.2 Cleaning the camera — page 96

## 19.1 Service and maintenance

This product contains no user serviceable components. Please refer all maintenance and repair to authorized FLIR dealers. Unauthorized repair may affect your warranty.

## 19.2 Cleaning the camera

The camera housing and lens will require occasional cleaning. You should clean the lens when image quality degradation is noticed or excessive contaminant buildup is seen. Clean the interface between the yoke and base often to prevent accumulation of debris or salt deposits.

When cleaning this product:

- Do NOT wipe the lens window with a dry cloth, or with abrasive materials such as paper or scrub brushes, as this could scratch the coating.
- Do NOT use acid or ammonia based products.
- Do NOT pressure wash.

Particular care should be taken when cleaning the lens window, this has a protective anti-reflective coating which may be damaged by improper cleaning.

1. Switch off the power to the unit.
2. Clean the camera body with a clean, soft cotton cloth. You can moisten the cloth and use a mild detergent if required.
3. Clean the camera lens.
  - Rinse the lens with fresh water to remove all dirt particles and salt deposits, and allow to dry naturally.
  - If any spots or smears remain, very gently wipe the lens window with a clean microfibre cloth or soft cotton cloth.
  - If necessary, use isopropyl alcohol (IPA) or a mild detergent to remove any remaining spots or marks.

# CHAPTER 20: SYSTEM CHECKS AND TROUBLESHOOTING

## CHAPTER CONTENTS

- 20.1 Thermal camera troubleshooting — page 98
- 20.2 Teledyne FLIR Maritime product support and servicing — page 99

## 20.1 Thermal camera troubleshooting

Problems with the thermal camera and their possible causes and solutions are described here.

### Camera not shown under your PC / laptop / tablet's device list:

Possible causes	Possible solutions
Incorrect setting configuration.	<p>Depending on your network configuration, it may take up to five minutes for the camera to appear in the list of devices. If the camera is not listed after five minutes, double-check that your IP address is configured as described in the following section: <a href="#">p.69 — Setting up a network connection to the camera</a></p> <p>Afterward, attempt to renew your IP device's IP address. For Windows 7, 8, and 10:</p> <ol style="list-style-type: none"> <li>1. Go to <i>[Start &gt; Run]</i>, then type "cmd" (without quotes), and click <i>[OK]</i>.</li> <li>2. In the Command Prompt window that opens, type "ipconfig /release" (without quotes), then press Enter.</li> <li>3. Type "ipconfig /renew" (without quotes), then press Enter.</li> <li>4. Type "exit" (without quotes), then press Enter to close the window.</li> </ol>

### Video not displayed:

Possible causes	Possible solutions
Camera is in Standby mode.	The camera will not display video if it is in Standby mode. Use the camera controls (either the thermal camera application or JCU) to "wake" the camera from standby.
Problem with the thermal camera network connections.	<ul style="list-style-type: none"> <li>• Check that the thermal camera network cables are sound and properly connected.</li> </ul>
Problem with power supply to the camera or JCU (if used as the primary controller)	<ul style="list-style-type: none"> <li>• Check the power connections to the camera and JCU / PoE injector (if used).</li> <li>• Ensure that the power switch / breaker is on.</li> <li>• Check the fuse / breaker state.</li> </ul>

### Erratic or unresponsive controls:

Possible causes	Possible solutions
Network problem.	Check that the controller and thermal camera are correctly connected to the network. (Note: This may be a direct connection or via a network switch.)
Control conflict, e.g. caused by multiple users at different stations.	Check the status of your network switch.
Problem with the controller.	Check that connected cables are free from damage.

### Image too dark or too bright:

Possible causes	Possible solutions
Display brightness is set too low.	Use the brightness controls at the display to adjust accordingly.
The Scene Mode is not appropriate for the current conditions.	A particular environment may benefit from a different Scene Mode setting. For example, a very cold background (such as the sky) could cause the camera to use a wider temperature range than appropriate.

### Image is inverted (upside down):

Possible causes	Possible solutions
Camera “Ball-down” setting is incorrect.	Ensure that the Ball down setting is set correctly.

## 20.2 Teledyne FLIR Maritime product support and servicing

Teledyne FLIR provides a comprehensive product support service, as well as warranty, service, and repairs. You can access these services through the Teledyne FLIR website, telephone, and e-mail.

For the latest support information go to [Support.FLIR.com/contact](http://Support.FLIR.com/contact)

### Product information

If you need to request service or support, please have the following information to hand:

- Product name.
- Product identity.
- Serial number.
- Software application version.
- System diagrams.

You can obtain this product information using the menus within your product.

### Servicing and warranty

Teledyne FLIR offers dedicated service departments for warranty, service, and repairs.

Don't forget to visit the Teledyne FLIR website to register your product for extended warranty benefits: <http://customer.flir.com/Warranty/EndUser-Registration>.

Region	Contact details
United Kingdom (UK), EMEA, and Asia Pacific:	<u>Telephone:</u> +44 (0)1329 246 932  <u>E-mail:</u> <a href="mailto:emea.service@flir.com">emea.service@flir.com</a>
United States (US):	<u>Telephone:</u> +1 (603) 324 7900  <u>E-mail:</u> <a href="mailto:rm-usrepair@flir.com">rm-usrepair@flir.com</a>

# CHAPTER 21: TECHNICAL SPECIFICATION

## CHAPTER CONTENTS

- 21.1 Physical specification — page 101
- 21.2 Power specification — page 101
- 21.3 Environmental specification — page 101
- 21.4 Video specification — page 102
- 21.5 Conformance specification — page 102
- 21.6 Sensor specification — page 103

## 21.1 Physical specification

Specification	
<b>Dimensions:</b>	Camera: <ul style="list-style-type: none"><li>• Base diameter: 222.2 mm (8.7 in.)</li><li>• Height: 328.3 mm (12.9 in.)</li></ul> Camera attached to mounting riser: <ul style="list-style-type: none"><li>• Base diameter (without seal): 252.3 mm (9.9 in.)</li><li>• Base diameter (with seal): 254.0 mm (10.0 in.)</li><li>• Height: 365.5 mm (14.4 in.)</li></ul>
<b>Weight (M300 C / M332 / M364):</b>	5.9 kg (12.9 lb) without mounting riser; 6.3 kg (13.9 lb) with mounting riser
<b>Weight (M364C / M364LR):</b>	6.3 kg (13.9 lb) without mounting riser; 6.75 kg (14.9 lb) with mounting riser
<b>Pan / tilt:</b>	<ul style="list-style-type: none"><li>• 360° continuous pan</li><li>• +/- 90° tilt</li></ul>

## 21.2 Power specification

Specification	
<b>Nominal supply voltage:</b>	12 to 24 V dc
<b>Operating voltage range:</b>	10.8 V to 31.2 V dc
<b>Current:</b>	Peak 10.0 A
<b>Power consumption:</b>	<ul style="list-style-type: none"><li>• 41 W typical</li><li>• 56 W max (with heaters on)</li></ul>

**Note:**  
It is recommended that you use a 75 W power supply

## 21.3 Environmental specification

Specification	
<b>Operating temperature:</b>	-25 °C to +55 °C (-13 °F to 131 °F)
<b>Storage temperature:</b>	-30 °C to +70 °C (-22 °F to 158 °F)
<b>Automatic window defrost:</b>	Standard at power-up (3 minute duration)
<b>Relative humidity:</b>	max 95%
<b>Water ingress protection:</b>	IPx6
<b>Wind:</b>	100 mph (161 kph)
<b>Vibration:</b>	<ul style="list-style-type: none"><li>• IEC/EN 60945:2002 (exposed)</li><li>• ABS IACS UR E10</li></ul>
<b>Salt Mist:</b>	IEC60945

## 21.4 Video specification

### Specification

- Video:**
- Video Resolution: 1920 x 1080 pixels (progressive scan)
  - IP digital video format: H264-encoded IP video stream, compatible with ONVIF Profile S
  - IP digital video format: MJPEG-encoded IP video stream (accessible via Web interface only)
  - HD-SDI digital video format: SMPTE-292M
- Visible light optical sensor:**
- Sensor resolution: refer to comparison table below
  - Field of View: refer to comparison table below
  - Optical Zoom: 30x
  - Digital Zoom: 12x
- Thermal sensor:**
- Sensor resolution: refer to comparison table below
  - Field of View (FOV): refer to comparison table below
  - Digital Zoom: 4x
- 

## 21.5 Conformance specification

### Specification

**Electromagnetic compliance:** EMI: IEC 60945

---

## 21.6 Sensor specification

Model	Visible light sensor		Thermal sensor	
	<i>Resolution</i>	<i>FOV</i>	<i>Resolution</i>	<i>FOV</i>
M332 (9 Hz) (E70528)	-	-	320 x 256 pixels	24° (H) x 18° (V)
M332 (30 Hz) (E70527)	-	-	320 x 256 pixels	24° (H) x 18° (V)
M364 (9 Hz) (E70526)	-	-	640 x 512 pixels	24° (H) x 18° (V)
M364 (30 Hz) (E70525)	-	-	640 x 512 pixels	24° (H) x 18° (V)
M300C (30 Hz) (E70605)	1920 x 1080 pixels	64° (H) x 60° (V)	-	-
M364C LR (9 Hz) (E70521)	1920 x 1080 pixels	64° (H) x 60° (V)	640 x 512 pixels	18° (H) x 13.5° (V)
M364C LR (30 Hz) (E70520)	1920 x 1080 pixels	64° (H) x 60° (V)	640 x 512 pixels	18° (H) x 13.5° (V)
M364C (9 Hz) (E70519)	1920 x 1080 pixels	64° (H) x 60° (V)	640 x 512 pixels	24° (H) x 18° (V)
M364C (30 Hz) (E70518)	1920 x 1080 pixels	64° (H) x 60° (V)	640 x 512 pixels	24° (H) x 18° (V)

# CHAPTER 22: SPARES AND ACCESSORIES

## CHAPTER CONTENTS

- 22.1 M300 Series camera spares and accessories — page 105
- 22.2 FLIR networking accessories — page 106
- 22.3 RayNet to RayNet cables and connectors — page 108
- 22.4 RayNet to RJ45, and RJ45 (SeaTalkhs) adapter cables — page 109

## 22.1 M300 Series camera spares and accessories

Item	Part number
RayNet (Ethernet) to RJ45 adapter cable, 120 mm (4.7 in).	A80513
RJ45 Coupler (Waterproof Enclosure).	4115028
JCU-1 remote control unit.	500-0385-00
JCU-2 remote control unit.	500-0398-10
JCU-3 remote control unit (with portrait and landscape keypad mats).	A80510
Power over Ethernet (PoE) 5-port network switch	4141042
12 V Power over Ethernet (PoE) Injector.	4113746

## 22.2 FLIR networking accessories

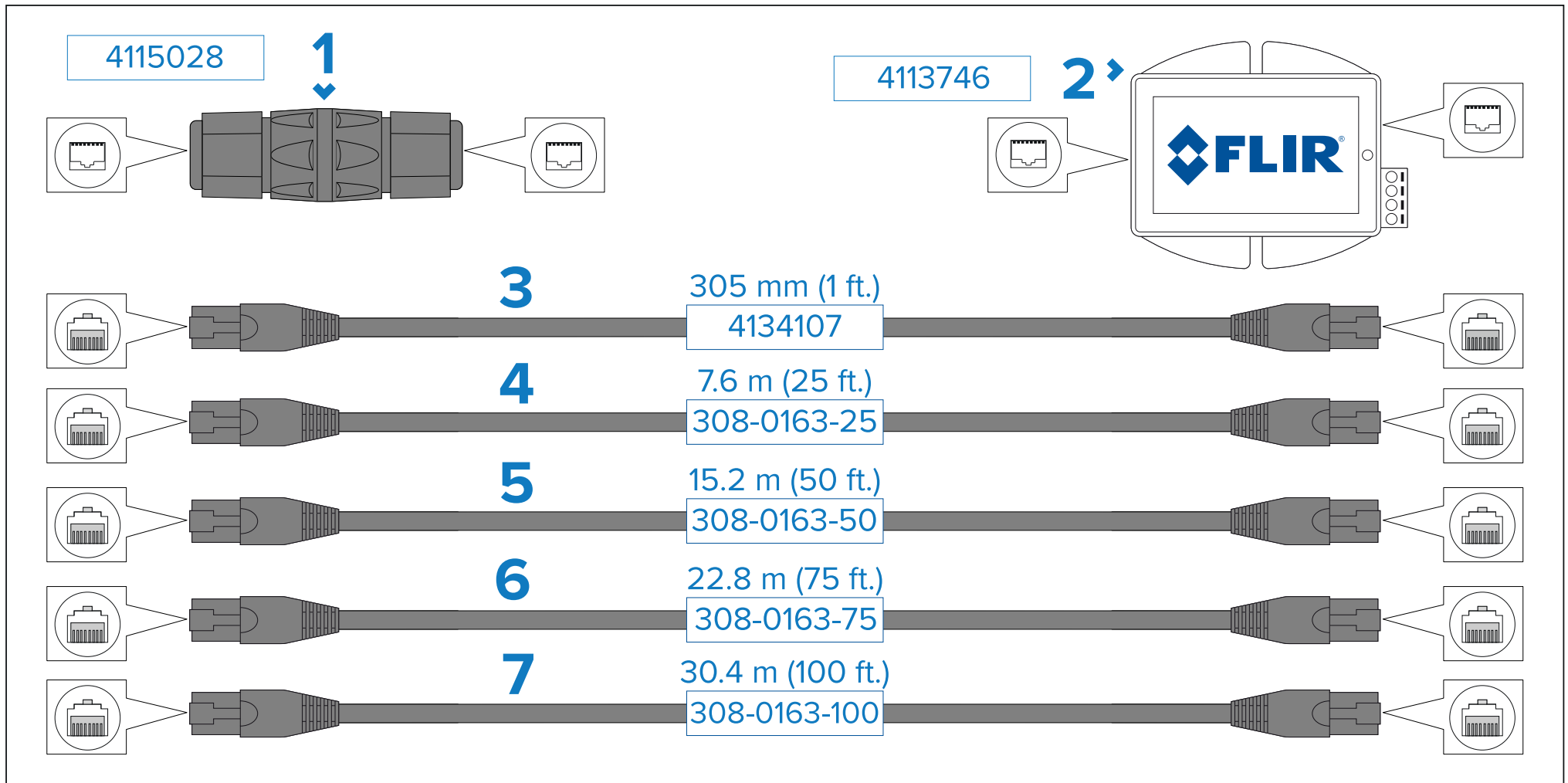

1. RJ45 coupler, for joining 2 separate RJ45 network cables together to achieve longer cable runs.
2. Power-over-Ethernet (PoE) injector. Supplies power to a non-PoE network connection. Typical use is for powering a JCU controller that is connected to a non-PoE network switch.
3. 305 mm (1 ft.) RJ45-to-RJ45 Ethernet cable, double shielded with LSZH low interference jacket.
4. 7.6 m (25 ft.) RJ45-to-RJ45 Ethernet cable, double shielded with LSZH low interference jacket.
5. 15.2 m (50 ft.) RJ45-to-RJ45 Ethernet cable, double shielded with LSZH low interference jacket.

6. 22.8 m (75 ft.) RJ45-to-RJ45 Ethernet cable, double shielded with LSZH low interference jacket.
7. 30.4 m (100 ft.) RJ45-to-RJ45 Ethernet cable, double shielded with LSZH low interference jacket.

## 22.3 RayNet to RayNet cables and connectors

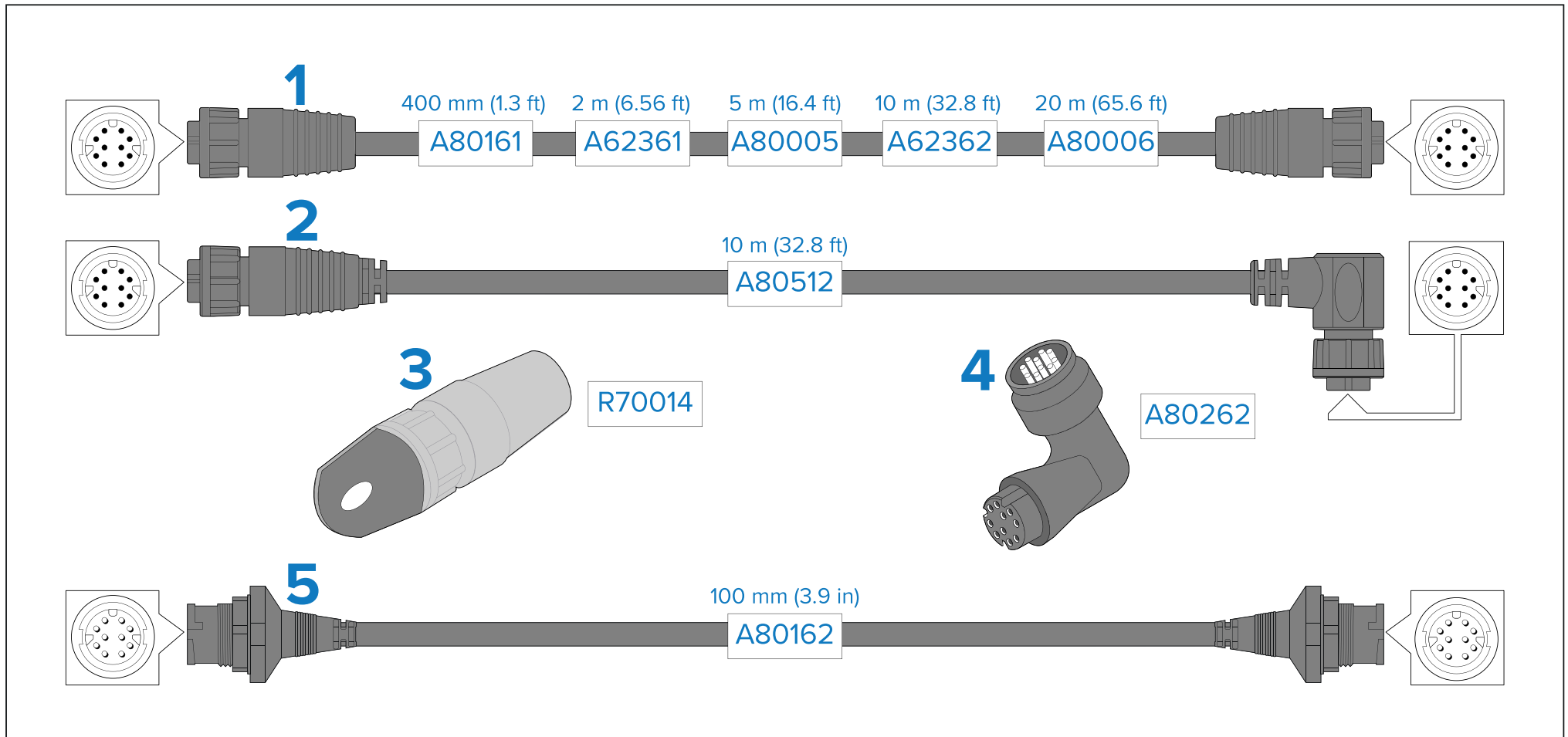

1. Standard RayNet connection cable with a RayNet (female) socket on both ends.
2. Right-angle RayNet connection cable with a straight RayNet (female) socket on one end, and a right-angle RayNet (female) socket on the other end. Suitable for connecting at 90° (right angle) to a device, for installations where space is limited.
3. RayNet cable puller (5 pack).
4. RayNet to RayNet right-angle coupler / adaptor. Suitable for connecting RayNet cables at 90° (right angle) to devices, for installations where space is limited.
5. Adapter cable with a RayNet (male) plug on both ends. Suitable for joining (female) RayNet cables together for longer cable runs.

## 22.4 RayNet to RJ45, and RJ45 (SeaTalkhs) adapter cables

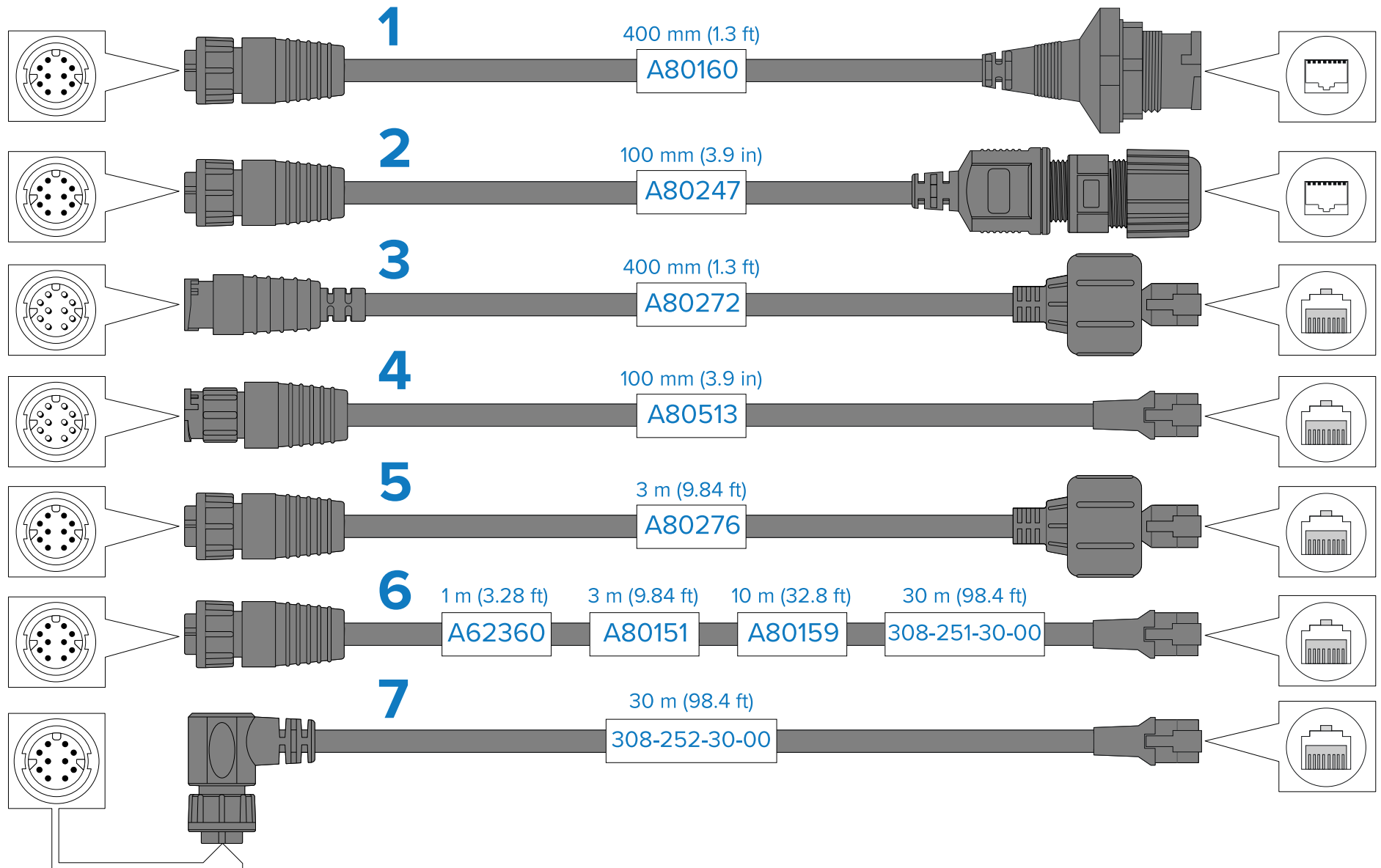

1. Adapter cable with a RayNet (female) socket on one end, and a waterproof (female) RJ45 (SeaTalkhs®) socket on the other end, accepting the following cables with an RJ45 (SeaTalkhs®) waterproof locking (male) plug:
  - A62245 (1.5 m).
  - A62246 (15 m).
2. Adapter cable with a RayNet (female) socket on one end, and a waterproof (female) RJ45 (SeaTalkhs®) socket on the other end, along with a locking gland for a watertight fit.
3. Adapter cable with a RayNet (male) plug on one end, and an RJ45 (SeaTalkhs®) waterproof (male) plug on the other end.
4. Adapter cable with a RayNet (male) plug on one end, and an RJ45 (male) plug on the other end.
5. Adapter cable with a RayNet (female) socket on one end, and an RJ45 (SeaTalkhs®) waterproof (male) plug on the other end.
6. Adapter cable with a RayNet (female) socket on one end, and an RJ45 (male) plug on the other end.
7. Adapter cable with a right-angled RayNet (female) socket on one end, and an RJ45 (male) plug on the other end.

## Appendix A Supported NMEA 0183 sentences

### Receive

- BWC (Bearing & Distance to Waypoint — Great Circle)
- GGA (Global Positioning System Fix Data)
- HDT (Heading — True)
- OSD (Own Ship Data)
- RDS (Radar System Data)
- RSD (Radar Cursor Data)
- TTM (Tracked Target Message)
- TLL (Target Latitude and Longitude)
- VHW (Water Speed and Heading)

## Appendix B Supported NMEA 2000 PGNs

### Transmit and Receive

- 59392 — ISO Acknowledgement
- 59904 — ISO Request
- 60416 — ISO Transport Protocol, Connection Management - BAM group function
- 60928 — ISO Address Claim
- 126720 — MDS
- 126996 — Product Information

### Transmit

- 126208 — NMEA - Acknowledge group function
- 126464 — Receive / Transmit PGNs Group Function
- 126993 — Heartbeat
- 126998 — Configuration Information

### Receive

- 60160 — ISO Transport Protocol, Data Transfer
- 65240 — ISO Commanded Address
- 126208 — NMEA — Command group function
- 127250 — Vessel Heading
- 127258 — Magnetic Variation
- 128520 — Tracked Target Data
- 128259 — Speed, Water Referenced
- 129029 — GNSS Position Data
- 129283 — Cross Track Error
- 129284 — Navigation Data



# Index

## A

Accessories .....	105
Network adapter cables .....	109
Network cables .....	108
Networking .....	106
RayNet cables.....	108
Applicable products .....	15

## B

Ball-down mode.....	66
Box contents, See Parts supplied (M300)	

## C

Cable	
Bend radius.....	39
Protection.....	39
Routing.....	39
Security.....	39
Strain relief.....	39
Camera control options .....	62
Camera image .....	62
Camera orientation .....	33
Ball-down .....	33
Ball-up.....	33
Color modes .....	65
Compass safe distance .....	30
Compatible hardware	
JCU .....	22
MFD .....	23
Connecting cables .....	38
Connection	
Power.....	57
Connections	
Battery.....	59
Distribution panel .....	58
General cabling guidance .....	38
Grounding .....	59

NMEA 0183.....	45
Contact details.....	99

## D

Declaration of Conformity .....	12
DeviceNet.....	37
Display options .....	21
Documentation	
Operation instructions .....	16

## E

Electromagnetic Compatibility .....	11
EMC, See Electromagnetic Compatibility	

## F

Forward position.....	67
-----------------------	----

## H

Home position.....	67
--------------------	----

## I

Installation	
Best practice .....	59
Camera orientation .....	33
Dimensions	
M300 .....	27
Mounting riser.....	28
Location requirements .....	30
Mounting .....	32
Mounting riser .....	27
Tools required .....	33
Interference .....	30
See also Compass safe distance	
IP address	
static.....	81

## J

JCU	
JCU-1.....	22
JCU-2.....	22
JCU-3.....	22
Overview.....	72
JCU-2	
Controls.....	83
UPBs.....	84

## L

Location requirements.....	30
Login	
change password.....	71

## M

Maintenance.....	10, 96
MFD	
Overview.....	87
Mounting.....	32
Multicast.....	22, 54–55

## N

Network	
cables.....	106, 109
PoE.....	106
switch.....	106
Network connections.....	19
Typical system.....	19
NMEA 0183.....	93–94
Baud rate.....	45
Radar cursor tracking.....	93–94
Slew to Cue.....	93–94
Slew to waypoint.....	93–94
Supported sentences.....	111
NMEA 0183 connection.....	45
NMEA 2000	
Supported PGNs.....	111
NMEA messages.....	64

## O

Operation	
Ball-down mode.....	66
Camera control options.....	62
Camera controls	
Forward position.....	67
Home position.....	67
Pan, tilt, zoom.....	66
Surveillance mode.....	67
Camera image.....	62
Color modes.....	65
JCU.....	72
MFD.....	87
Reverse video.....	65
Scene presets.....	65
Status icons.....	62
Thermal camera.....	62
Web browser.....	69
Operation instructions.....	16

## P

Pan, tilt, zoom.....	66
Parts supplied (M300).....	25
Password change.....	71
Power	
Battery connection.....	59
Distribution.....	57
Distribution panel.....	58
Fuse and breaker ratings.....	57
Grounding.....	59
Sharing a breaker.....	58
Power connection.....	57
Product overview.....	18–19
Dual payload.....	19
Single payload.....	18
Product recycling (WEEE).....	12
Product support.....	99

## R

Radar cursor tracking.....	93–94
----------------------------	-------

RayNet	
cables.....	108–109
Reverse video.....	65
RJ45	
cables.....	109

## S

Scene presets.....	65
SeaTalkhs	
cables.....	109
Service Center.....	99
Servicing.....	10, 96
Slew to Cue.....	93–94
Slew to waypoint.....	93–94
Spares.....	105
Status icons.....	62
Suppression ferrites.....	11
<i>See also</i> EMC	
Surveillance mode.....	67
System settings.....	81

## T

Technical specification	
Conformance specification.....	102
Environmental specification.....	101
Physical specification.....	101
Power specification.....	101
Video specification.....	102
Technical support.....	99
Thermal camera.....	62

## W

Warranty.....	99
Web browser	
Log in.....	70
network connection setup.....	69
Overview.....	69
Settings.....	75
WEEE Directive.....	12





**USA**

Teledyne FLIR LLC  
110 Lowell Road,  
Hudson, NH 03051.  
United States of America

**EUROPE**

Teledyne FLIR LLC  
Marine House, Cartwright Drive  
Fareham, PO15 5RJ  
United Kingdom



**TELEDYNE  
FLIR**  
Everywhereyoulook™

